

**ELEMENTS OF  
AIRCRAFT  
POLLUTION**



# **ELEMENTS OF AIRCRAFT POLLUTION**

**G.J.J. Ruijgrok**

Professor of aerospace engineering  
Faculty of Aerospace Engineering  
Delft University of Technology  
Professor Emeritus, Brussels Free University

**D.M. van Paassen**

Lecturer  
Faculty of Aerospace Engineering  
Delft University of Technology

**VSSD**



© G.J.J. Ruijgrok en D.M. van Paassen  
2007

Published by VSSD  
Leeghwaterstraat 42, 2628 CA Delft, The Netherlands  
tel. +31 15 27 82124, telefax +31 15 27 87585, e-mail: [hlf@vssd.nl](mailto:hlf@vssd.nl)  
internet: <http://www.vssd.nl/hlf>  
URL about this book: <http://www.vssd.nl/hlf/ae01.htm>

All rights reserved. No part of this publication may be reproduced, stored in a retrieval system, or transmitted, in any form or by any means, electronic, mechanical, photocopying, recording, or otherwise, without the prior written permission of the publisher.

Printed student edition:  
ISBN-10 90-71301-71-0  
ISBN-13 978-90-71301-71-1

Electronic version:  
ISBN-10 90-71301-92-3  
ISBN-13 978-90-71301-92-6

NUR 968

Key words.: aircraft pollution



# CONTENTS

<b>PREFACE</b>	<b>xi</b>
<b>1 INTRODUCTION</b>	<b>1</b>
1.1 Air pollution	1
1.2 Chemical composition of clean air	3
1.3 Arrangement and nomenclature of the atmosphere	5
1.4 Harmful effects of engine emissions	12
1.5 Motor vehicle emissions	16
1.6 Aero-engine emissions	18
1.7 The hydrological cycle	20
1.8 Tidal currents	25
1.9 The SI-system of units	30
1.10 Pollutant concentration	32
<b>2 NATURE OF THE ATMOSPHERE</b>	<b>33</b>
2.1 Application of Newton's law of motion	33
2.2 The seasons	36
2.3 Acceleration of gravity	38
2.4 Variation of air pressure and density with altitude	40
2.5 Air masses and fronts	43
2.6 Geostrophic wind	47
2.7 Small-scale air motions	52
2.8 The vertical wind gradient near the ground	54
2.9 Turbulence and gusts	58
<b>3 STANDARD ATMOSPHERES</b>	<b>60</b>
3.1 The International Standard Atmosphere	60
3.2 Off-standard atmospheric conditions	64
3.3 U.S. Standard Atmosphere, 1962	70
3.4 U.S. Standard Atmosphere, 1976	83

<b>4</b>	<b>MOIST AIR</b>	<b>86</b>
4.1	Saturation vapor pressure	86
4.2	Measures for the water content	88
4.3	The vertical stability of the atmosphere	92
4.4	Cloud formation	103
4.5	Precipitation and wind	106
4.6	Self-cleaning capability of the atmosphere	112
<b>5</b>	<b>SOLAR ENERGY</b>	<b>122</b>
5.1	Electromagnetic radiation	122
5.2	Solar radiation	125
5.3	Reflection and refraction of sunlight	130
5.4	Radiation balance of Earth and atmosphere	136
5.5	The concept of radiative forcing	140
5.6	The concept of global warming potential	141
5.7	Greenhouse gases	142
5.8	The ozone layer	145
<b>6</b>	<b>ENVIRONMENTAL MAJOR CONCERNS</b>	<b>149</b>
6.1	Air pollutants	149
6.2	Toxic substances	154
6.3	Tropospheric ozone formation	156
6.4	The enhanced greenhouse effect	162
6.5	Acidification and acid rain formation	168
6.6	Stratospheric ozone depletion	171
<b>7</b>	<b>FUNDAMENTALS OF JET PROPULSION</b>	<b>177</b>
7.1	Types of jet propulsion systems	177
7.2	Definition of thrust	180
7.3	The first and second law of thermodynamics	182
7.4	The flow energy equation	187
7.5	The ideal turbojet cycle	192

7.6	Component efficiencies	201
7.7	Isentropic flow through a channel of varying cross section	208
7.8	Flow conditions at the nozzle exit	210
<b>8</b>	<b>PERFORMANCE OF TURBOFAN AND TURBOJET ENGINES</b>	<b>215</b>
8.1	Turbofan engine design point performance	215
8.2	Compressor characteristics	222
8.3	The axial flow turbine	228
8.4	Off-design performance	231
8.5	Off-design performance prediction	239
8.6	Generalized performance presentation	245
<b>9</b>	<b>PROPELLER PROPULSION</b>	<b>249</b>
9.1	Propeller propulsion systems	249
9.2	The turboprop engine	251
9.3	The piston engine	256
9.4	Measurement of shaft power	261
9.5	Piston engine performance charts	263
9.6	Propeller thrust and efficiency	266
9.7	Propeller geometry	270
9.8	Propeller charts and types	274
<b>10</b>	<b>POLLUTANT EMISSIONS OF AERO-ENGINES</b>	<b>280</b>
10.1	The combustor	280
10.2	Combustion of hydrocarbon fuels	282
10.3	Heating value	291
10.4	Formation of undesired combustion products	293
10.5	Emission certification	296
10.6	Relations for the emission of nitrogen oxides	300
10.7	NO <sub>x</sub> reduction in aero-engines	306
10.8	Aircraft contrails	309
10.9	Climate effect estimates	312

<b>11</b>	<b>FLIGHT PERFORMANCE</b>	<b>316</b>
11.1	Introduction	316
11.2	Path and point performance in symmetric flight	318
11.3	Fuel load	321
11.4	Takeoff and landing	323
11.5	The performance diagram	326
11.6	Path performance in climbing and descending flight	332
11.7	Range and endurance	334
11.8	Optimum cruise altitude	337
11.9	Numerical calculations	340
11.10	Tankering	342
11.11	Effect of wind	344
11.12	Effect of climb and descent on range performance	345
11.13	Payload-range relationship	346
11.14	Economic performance parameters	348
11.15	Direct operating cost	350
11.16	Pollution number	352
<b>12</b>	<b>OPERATION AND DESIGN FOR LOW EMISSIONS</b>	<b>354</b>
12.1	High altitude emissions from transport aircraft	354
12.2	Effect of cruise conditions on NO <sub>x</sub> emissions	359
12.3	Fuel conservation	363
12.4	Lift and drag	368
12.5	Wing design for low pollution	379
12.6	Weight reduction	383
12.7	Alternative fuels for future transport airplanes	387
12.8	Sustainable development	390
	<b>REFERENCES</b>	<b>393</b>
	<b>INDEX</b>	<b>398</b>

## PREFACE

Within the last few decades, concern about the environmental conditions on Earth has grown steadily as it has been recognized that the exhaust of pollutant emissions from burning fossil fuels into the atmosphere cannot be allowed to continue unlimitedly. The two environmental problems currently causing most concern are the global changes in the climate due to the enhanced greenhouse effect and the depletion of the stratospheric ozone layer.

This has also raised the question on the effects of emissions from aircraft upon the atmosphere. In addition to carbon dioxide,  $\text{CO}_2$ , and water vapor,  $\text{H}_2\text{O}$ , the emissions of carbon monoxide,  $\text{CO}$ , unburned hydrocarbons (UHC), nitrogen oxides,  $\text{NO}_x$ , and smoke or soot are the essence of the problem of air pollution caused by aviation.

Although the total quantity of emissions from air traffic is very small compared to other man-made emissions, their impact on the environment may not be negligible. Important is the fact that aircraft emissions are the only significant anthropogenic source of pollutants in the upper troposphere and lower stratosphere. Also of importance is the fact that the demand for air travel is still growing.

Carbon dioxide and water vapor are important greenhouse gases. In addition, there is evidence that due to the exhaust of water vapor by aero-engines, the cloud cover of the Earth is increased to a certain extent by contrail-induced cirrus. Also the exhaust of nitrogen oxides is a matter of major concern because this compound may promote the enhanced greenhouse effect and as well as depletion of ozone in the stratosphere. An enhanced greenhouse effect means that the world is becoming warmer, while a depletion of the stratospheric ozone layer will cause a harmful level of ultraviolet (UV) radiation at the surface of the Earth.

This book, especially, is concerned with the numerous sciences and technologies which make up the air pollution problem from flight operations, giving special attention to the performance and emissions of airplanes at their cruise altitudes. Obviously, a good knowledge of the different subjects involved is a prerequisite for obtaining an understanding of human influence on the environment.

The contents of the book are a reflection of an annual course on propulsion, noise, and aircraft pollution, presented by the author to MSc Aerospace Engineering students at Delft University of Technology.

The author is grateful and happy to share the responsibility for the part performance in the book with his coauthor Mr. D.M. van Paassen, lecturer/pilot at Delft University of Technology.

## x ELEMENTS OF AIRCRAFT POLLUTION

The book is an attempt to place the question of *aircraft pollution* in the context of aerospace engineering by bringing together the most relevant topics covering the problem. To this end, many sources have been consulted because much of the material could only be obtained from textbooks, reports, and articles. The references to the literature are indicated in the text and listed at the end of the book. It should be mentioned, however, that the current state of knowledge of the effects of aviation upon the global atmosphere is described comprehensively in the Intergovernmental Panel on Climate Change Special Report (Ref.1). This IPCC report also makes clear that the effect of aviation on the environment is a complex problem, drawing upon several widely-different scientific disciplines.

In the book the International System of units (SI units) has been used throughout. A point to note is that in international civil aviation the use of certain non-SI units is prescribed, such as foot instead of meter for flight altitude, and so these units also have been cited in the text.

No claim to be comprehensive is made for the book, but it is hoped that no major part of the problem has been omitted from consideration. Above all, it is hoped that the contents of the book will somewhat clarify the various subjects and may urge the reader to further study in this field.

Delft, February 2005

G.J.J. Ruijgrok  
D.M. van Paassen

# 1 INTRODUCTION

## 1.1 AIR POLLUTION

When the natural composition of the atmosphere is changed, the air is considered to be polluted. Air pollution is recognized as one of the world's most serious environmental problems, and includes both natural sources and anthropogenic sources (pollutants from human activities).

Sometimes it only manifests itself by an oppressive odor, however, often it concerns environmentally harmful substances for human beings, animals and vegetation.

In brief, air pollution may appear in the following forms:

- Unpleasant stench or odor nuisance.
- Small droplets, gases, and fumes.
- Particulate matter, PM (any airborne, finely divided, liquid or solid material).

As depicted in Figure 1.1-1, the order of magnitude of particulates varies from  $10^{-9}$  to  $10^{-2}$  m. The smallest particulates are called *aerosols* ( $10^{-9}$  to  $10^{-6}$  m), and are able to penetrate into our respiratory system. Aerosols involve extremely fine dust or droplets of microscopic size such as tobacco smoke and soot. By soot are meant the carbon-containing particles resulting from incomplete combustion of hydrocarbon fuels. Dust, having particulate sizes ranging from  $10^{-6}$  to  $10^{-2}$  m, refer to, for example, fly ash, coal dust, sand, and rain drops (Ref. 2).

This stuff, whether natural or man-made, stimulates the condensation of moist air a great deal. In the absence of condensation nuclei the air may remain supersaturated (see Chapter 4).

Natural sources of air pollution are:

- Volcanic eruptions, emitting a variety of gases and particles into the atmosphere. These include water vapor  $H_2O$ , carbon monoxide  $CO$ , carbon

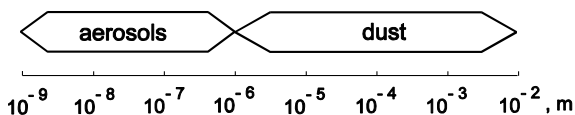

Figure 1.1-1. Particulate sizes.

dioxide  $\text{CO}_2$ , sulfur dioxide  $\text{SO}_2$ , nitrogen oxides  $\text{NO}_x$  ( $\text{NO}$  and  $\text{NO}_2$ ), mercury  $\text{Hg}$ , hydrogen sulfide  $\text{H}_2\text{S}$ , hydrochloric acid  $\text{HCl}$ , and dust particles.

- Saline droplets arising from the oceans.
- Organic byproducts of biological activities and vegetable substances, such as pollen, ammonia  $\text{NH}_3$ , nitrous oxide  $\text{N}_2\text{O}$ , methane  $\text{CH}_4$ , and hydrogen sulfide  $\text{H}_2\text{S}$ .
- Dust storms.

Examples of anthropogenic forms of pollutants are combustion products of fossil fuels for power and heat generation. Other forms are residues from refineries and industrial processes. Note that petroleum and natural gas contain no fossils, because of the extreme conditions under which they have been formed. Identifiable fossils may only be found in coal and peat.

In residential areas the exhaust gas emissions near ground level from road traffic will considerably contribute to air pollution through the combustion of gasoline, diesel, and liquefied petroleum gas (LPG).

Figure 1.1-2a shows the world population increases since the year one (Ref. 9). The explosive growth of human population of the twentieth century is obvious. Figure 1.1-2b portrays the growth in world population and global number of motor vehicles since 1970 and projections to 2030, showing that the current number of vehicles may double in the next 30 years.

The number of cars per 1000 inhabitants varies substantially per country. In 1992 the number of vehicles per 1000 inhabitants was approximately 550 in the

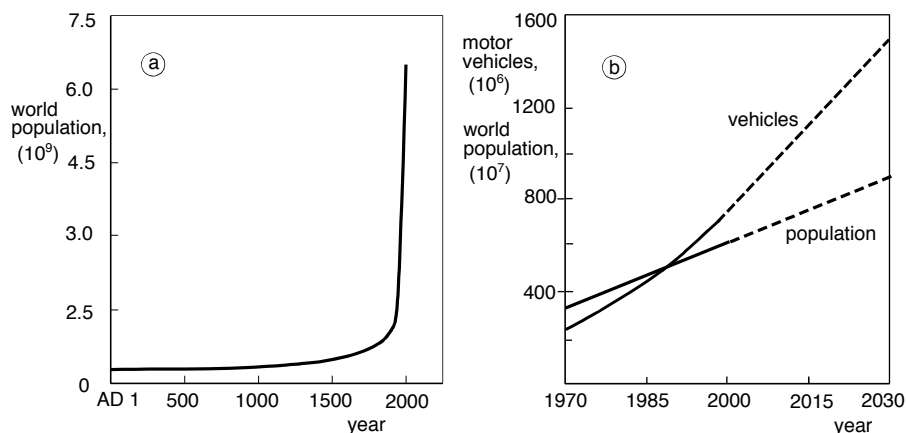

Figure 1.1-2. World population and global number of motor vehicles.

United States, in Western Europe 200 - 400, while in Africa it was only 9, in India 2, and in China 0.4 (Ref. 3). As noticed earlier, the exhaust gases of motor vehicles are particularly harmful because the emissions take place in the environment in which we live. In urban environments, where dispersion barely takes place, high concentrations of pollutants may occur.

The air polluting substances from automobiles and trucks are, besides water vapor  $H_2O$  and carbon dioxide  $CO_2$ , carbon monoxide  $CO$ , nitrogen oxides  $NO_x$  ( $NO$  and  $NO_2$ ), aerosols, sulfur oxides  $SO_x$  ( $SO_2$  and  $SO_3$ ), lead  $P_b$ , unburned hydrocarbons (UHC) and soot particles. Substances that evaporate at temperatures less than about  $100^\circ C$ , are called *volatiles*, e.g., benzene  $C_6H_6$ .

Also, the emission of sulfur, nitrogen oxides, and dust by shipping delivers a noticeable contribution to air pollution.

It should be noted that when considering the environmental effects of electrical systems of transportation, the environmental impact of power generation for their propulsion should also be taken into account, as it contributes likewise to air pollution.

Besides primary pollutants, those emitted directly from the source, secondary pollutant species may be formed. The latter arise from mutual chemical reactions involving originally discharged pollutants. This is called *secondary air pollution*.

## 1.2 CHEMICAL COMPOSITION OF CLEAN AIR

Air is a mixture of gases. The total mass of the atmosphere is approximately  $5.30 \times 10^{18}$  kg. For comparison, the mass of the Earth is  $5.98 \times 10^{24}$  kg and the total mass of the water on the Earth is  $1.39 \times 10^{21}$  kg. More than 97% of the water is stored in seas and oceans. The atmosphere contains only about 0.035 percent of the water.

The bulk of the air mass is concentrated in the lower layers of the atmosphere as the air density becomes gradually lower with increasing height. For example, 50% of the atmosphere's mass is contained within the first 6 km and 95% is concentrated below a height of 22 km. If the total air mass would be converted to mean sea-level pressure and temperature, a layer of just about 8 km would remain.

In Table 1.2-1 the chemical composition of clean air near the Earth's surface is listed (Ref. 4). Evidently, the air we breathe at sea level consists for the greater part of the two diatomic gases nitrogen  $N_2$  and oxygen  $O_2$  (together about

constituent gas		content, percent by volume	molecular mass kg/kmol
Nitrogen	N <sub>2</sub>	78.084	28.0134
Oxygen	O <sub>2</sub>	20.9476	31.9988
Argon	Ar	0.934	39.948
Carbon dioxide	CO <sub>2</sub>	0.0314	44.00995
Neon	Ne	0.001818	20.183
Helium	He	0.000524	4.0026
Methane	CH <sub>4</sub>	0.0002	16.04303
Krypton	Kr	0.000114	83.80
Sulfur dioxide	SO <sub>2</sub>	0-0.0001	64.0628
Hydrogen	H <sub>2</sub>	0.00005	2.01594
Nitrous oxide	N <sub>2</sub> O	0.00005	44.0128
Xenon	Xe	0.0000087	131.30
Ozone	O <sub>3</sub>	0-0.000007	47.9982
Nitrogen dioxide	NO <sub>2</sub>	0-0.000002	46.0055
Iodine	I <sub>2</sub>	0-0.000001	253.8088
Water vapor	H <sub>2</sub> O	0-3.0	18.0

Table 1.2-1. Normal composition of clean atmospheric air near sea level.

99.03% by volume). Oxygen, O<sub>2</sub>, the second largest constituent, is one of the most reactive elements.

The remaining constituents, although present in relatively small quantities, may be nevertheless of great importance. For instance, the ample quantities of carbon dioxide CO<sub>2</sub> and water vapor H<sub>2</sub>O form a kind of shield, blocking the heat radiation from the Earth into outer space and heating up the Earth's surface. This phenomenon is called the *natural greenhouse effect*, the condition that keeps an enclosure warm in the wintertime.

Ozone, O<sub>3</sub>, is present everywhere in the atmosphere. However, the amount of ozone varies significantly, geographically, with seasons, and, typically, depends strongly on the altitude.

Ozone is an unstable gas, formed by reaction of molecular oxygen O<sub>2</sub> and atomic oxygen O. Atomic oxygen arises from dissociation of molecular oxygen, caused by ultraviolet solar radiation.

Simultaneously, ozone depletion takes place, forming molecular and atomic oxygen, caused by infrared radiation. This continuous process of formation and depletion results in a constant overall equilibrium concentration of ozone in the

atmosphere. Depending on the intensity of the solar radiation and the number of particles per unit volume, a maximum in the ozone concentration occurs at an altitude between 25 and 35 km.

Important is that the ozone at these high altitudes acts as a filter against solar ultraviolet radiation, which otherwise has many harmful effects on Earth's animal and plant life.

Water in the atmosphere can be present in the form of water vapor, an invisible gas, or as minute droplets and ice particles (clouds, precipitation).

The amount of water vapor varies with geographical latitude, and decreases substantially with increasing altitude. Generally, the highest degree of humidity occurs near the Equator. At an altitude of 10 km virtually no water vapor is found.

The composition of the air remains more or less constant up to an altitude of about 90 km. Above this altitude the composition gradually changes, mainly because of molecular dissociation, i.e., the break up of the molecules of the various gases into their atoms, called *radicals*, due to the increased intensity of ultraviolet sunlight. In consequence, the molecular mass of the air decreases with increasing altitude.

### 1.3 ARRANGEMENT AND NOMENCLATURE OF THE ATMOSPHERE

With respect to the chemical composition, the atmosphere may be classified into the *homosphere* and the *heterosphere*. The homosphere extends up to an altitude of 90 km, where the air is characterized by a nearly constant chemical composition (with the exception of water vapor and ozone). The region above 90 km is indicated as the heterosphere. Here, the molecular mass decreases from about 29 kg/kmol at a height of 90 km, to 18 kg/kmol at a height of 500 km. The dividing plane between the homosphere and heterosphere is known as the *homopause*.

In Figure 1.3-1 the typical variation of the average temperature with altitude is sketched. Based on this temperature distribution, the atmosphere can be divided into the following four layers:

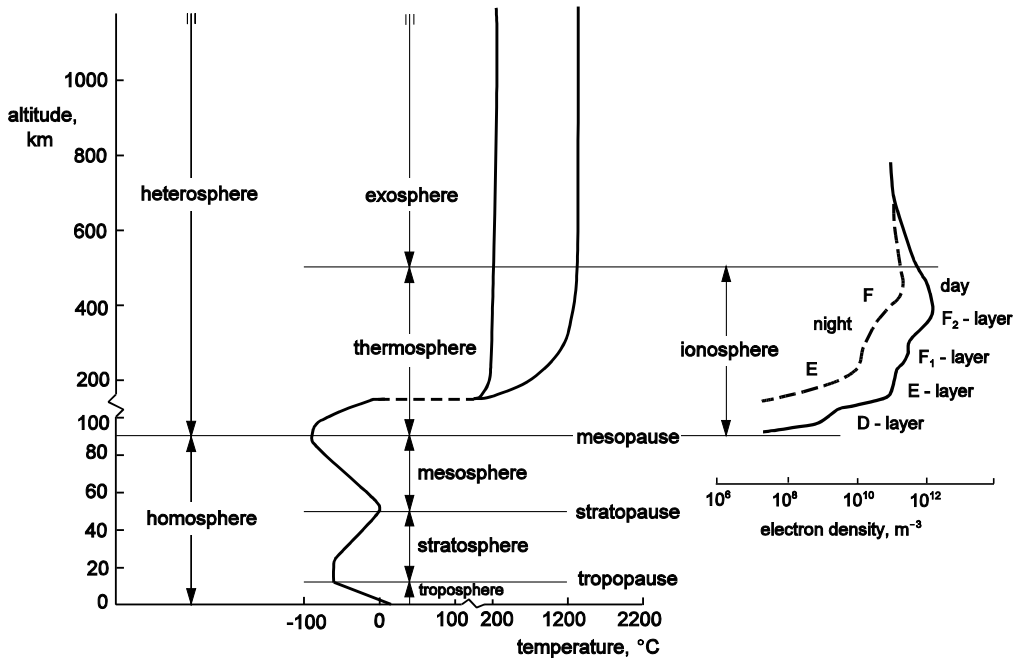

Figure 1.3-1. The nomenclature of the atmosphere.

- Troposphere.
- Stratosphere.
- Mesosphere.
- Thermosphere.

The *troposphere* is characterized by a decrease in temperature with increasing altitude. In this layer occur the phenomena which we call *weather*, i.e., the local state of temperature, pressure, humidity, cloudiness, wind, and precipitation.

The troposphere can be subdivided into two parts (Figure 1.3-2). The first part, up to about 2 km above sea level, is called the *planetary* or *atmospheric boundary layer* and the remaining part is named the *free troposphere*. This distinction is of significance when considering the effects of air pollution, since the atmospheric boundary layer is most directly influenced by the underlying land or sea surface.

The dividing plane between the troposphere and the *stratosphere* is called the *tropopause*. For average latitudes, this plane is located at a height of about 11

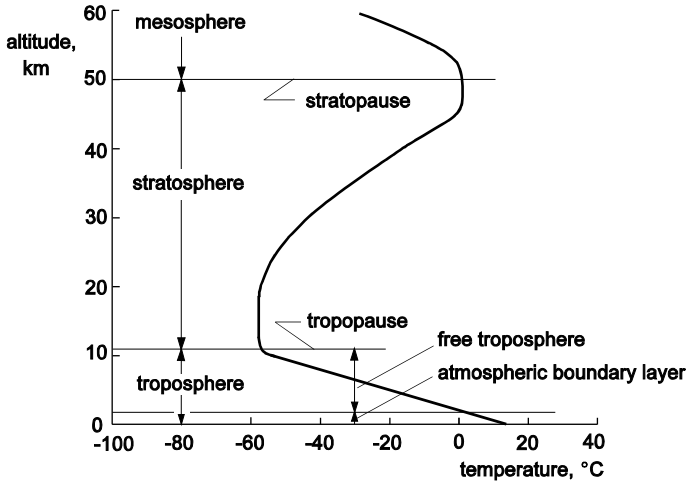

Figure 1.3-2. Temperature rates in the atmosphere.

km. Near the polar regions it is located at about 8 km, while at the Equator it reaches up to approximately 17 km ( Figure 1.3-3).

In the stratosphere, at first, there is a nearly constant temperature of about  $-50$  to  $-60^{\circ}\text{C}$  up to an altitude of 20 to 25 km. From thereon the temperature increases to a maximum value of  $0^{\circ}\text{C}$  at an altitude of about 50 km. The dividing plane between the stratosphere and the *mesosphere* is called the *stratopause*. This altitude sometimes is referred to as the *ozonepause*. In fact, the temperature increase above 20 km is related to the absorption of ultraviolet radiation, involving ozone formation.

Typical for the mesosphere is a decreasing temperature, reaching a minimum value of about  $-90^{\circ}\text{C}$ , at an altitude of 90 km. The latter altitude is called the *mesopause*.

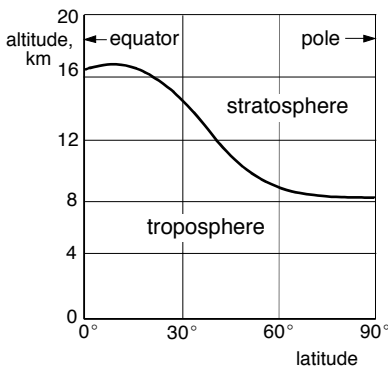

Figure 1.3-3. Impression of tropopause level variation.

altitude [km]	number of particles, m <sup>-3</sup>
0	$2.5 \times 10^{25}$
10	$10^{25}$
500	$10^{14}$
1000	$10^{12}$
1500	$10^{11}$
2000	$10^{10}$

Table 1.3-1. Number of particles per cubic meter for several altitudes.

The region between 90 and about 500 km is called the *thermosphere*. In the thermosphere, the temperature increases quickly with increasing altitude until at about 500 km the so-called *exospheric temperature* is reached. Depending on solar activity, the value of this temperature may vary between 200 and 1000°C. These temperatures are only an indication of the kinetic energy of the air particles. The temperature of an object at these very high altitudes is entirely determined by the heat balance between its absorbed heat radiation, its produced internal heat and its emitted heat radiation. Convective heat transfer is hardly possible due to the very low value of the air density.

From 90 km upwards, ionization processes occur, i.e., the generation of ions and the accompanying free electrons takes place. Therefore, in Figure 1.3-1 also is depicted the *ionosphere*, in which the highest concentrations of ions are found. Also the ionosphere extends roughly from a height of 90 to 500 km. Depending on electron density, the ionosphere is subdivided into four layers, designated D, E, F<sub>1</sub> and F<sub>2</sub>. The curves in Figure 1.3-1 show that the extent of ionization increases with altitude up to approximately 300 km. Local maxima of the amount of ionized particles occur, corresponding to the four layers. At night, when no radiation is perceived, some of these sub-layers may be absent. The curves also vary with solar activity and time of the year.

As depicted in Figure 1.3-4, due to its ability to reflect electromagnetic radiation, the ionosphere is of paramount importance to long-distance radio communication using wavelengths greater than 10 m.

At altitudes above 500 km, where the air density decreases further, the number of particles per unit volume becomes extremely low. By way of illustration, Table 1.3-1 gives the number of particles per unit of volume for several altitudes.

Consequently, the particles will show large *mean free path lengths* of several hundreds of kilometers or even more. Hence, particle collisions are unlikely to take place.

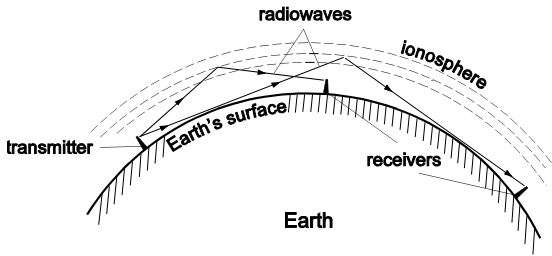

Figure 1.3-4. Long-range radio communication.

At a height of 500 km begins the region that is called the *exosphere*, where collisions between molecules are so rare that neutral particles move in trajectories which are subject to gravity only. Almost all the atmospheric gases are ionized, and the charged particle motions are strongly directed by the magnetic field surrounding them.

In the exosphere the distribution of the gases is controlled by *diffusion*, which process implies that a substance moves from a region where its concentration is high to one where its concentration is low. As a result, a transition from mainly atomic oxygen ions into primarily helium ions takes place at about 1000 km, and from helium ions to the lighter hydrogen ions at heights of the order of 3000 km.

Clearly, a knowledge of the Earth's magnetic field is a prerequisite to an appreciation of exospheric motions. To this end, we have to consider the *magnetosphere*, which region refers to the magnetic properties of the Earth. Near the Earth's surface, the magnetic field of the Earth may be represented by

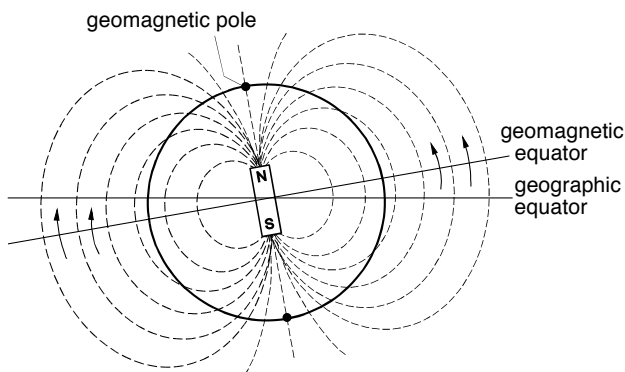
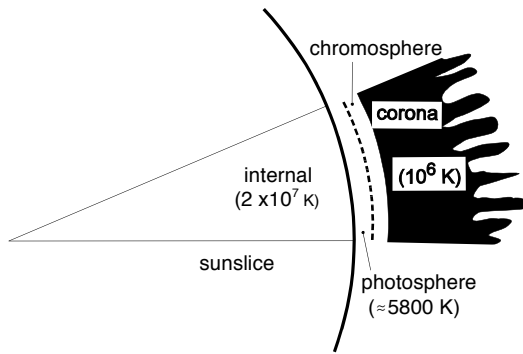

Figure 1.3-5. Magnetic field near the Earth's surface.



The apparent visible surface of the Sun, known as the *photosphere*, consists of a network of bright markings on a darker background. The effective temperature in the photosphere amounts to about 5800 K. The portion of the Sun's atmosphere nearest the photosphere, called the *chromosphere*, is a layer of ionized gases extending to several thousand miles. The energy radiated by the Sun is the result of nuclear processes in the interior, where helium is formed by the fusion of hydrogen nuclei. In the Sun's core, the temperature rises to about 20 million kelvin.

Figure 1.3-6. Structure of the Sun.

the dipole field of a bar magnet (Figure 1.3-5). The axis of the dipole is not aligned with the polar axis of the Earth, but is inclined to it at an angle of about  $11.3^\circ$ . Drawing a straight line through approximately the center of the Earth along the dipole axis yields the two geomagnetic poles at the points where this line breaks through the Earth's surface. A compass needle will follow the magnetic field lines, which run from one pole to the other.

Of course, the magnetic field of the Earth is three-dimensional and extends more or less spherically from the magnet, the lines of force converging at the two magnetic poles.

From rocket and satellite observations it is known that at very large heights the magnetic field is flattened on the side of the Earth turned toward the Sun and stretched out on the night side.

This transformation of the Earth's magnetic field arises from its interaction with the *solar wind*, which is a stream of charged particles. The solar wind is emitted from the outermost layer of the Sun's atmosphere, the solar *corona*, which consists of an extensive, very tenuous envelope of gases at high temperature (Figure 1.3-6).

Although the Sun has a strong gravitational field, its enormous high temperature contains enough kinetic energy that the particles can escape from the Sun into the interplanetary space.

The solar wind is composed almost of protons and electrons, which particles are electrically charged. Protons carry a positive charge and electrons a negative charge. Their travel speeds vary between 300 and 1000 km/s, depending on solar activity.

When the solar wind strikes the magnetic field of the Earth, a bow shock wave is generated, changing the shape of the Earth's magnetic field. The resultant

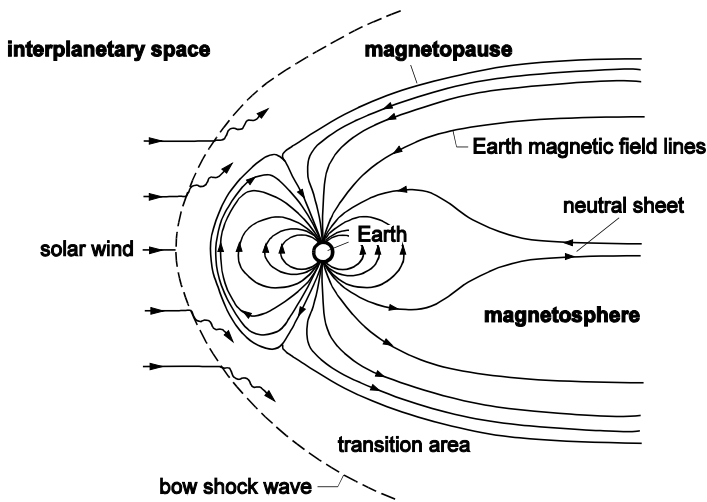

Figure 1.3-7. The magnetosphere.

distortion is sketched in Figure 1.3-7, giving a two-dimensional representation of the *magnetosphere*, the three-dimensional magnetic field that surrounds the Earth. Figure 1.3-7 also shows that the Earth's magnetic field is enclosed by the solar wind with the *magnetopause* as a quite definite boundary.

The electrically charged particles of the solar wind are trapped in the magnetosphere. The forces acting, cause them to follow spiral paths along lines of force. Charged particles are most abundant in a concentric series of belts, shaped like tires which surround the Earth, located over the Equator. These belts are known as the *Van Allen radiation belts*, named after the American physicist James A. Van Allen (b. 1914), who discovered their occurrence from information gathered by *Explorer I*, the first American satellite (1958).

The particles of the solar wind that carry no charges (neutrons) are also trapped by the magnetosphere, but at a lower level. They also penetrate the magnetosphere but, as they move toward the Earth, they collide with atoms of atmospheric gases, producing elementary particles.

The charged particles making up the Earth's exosphere are not able to escape from the magnetosphere, so that the magnetopause can be regarded to be the outermost part of the Earth's atmosphere.

The electromagnetic radiation coming from the Sun is not affected by the presence of the magnetosphere. As will be discussed in Chapter 5, their fate is especially governed by their frequencies.

## 1.4 HARMFUL EFFECTS OF ENGINE EMISSIONS

The various pollutants from burning fossil fuels may contribute to the following five principal effects of air pollution:

1. Effects on the climate.
2. Acidification.
3. Ozone layer breakdown.
4. Photochemical air pollution.
5. Local effects at ground level.

Each of these effects is briefly discussed below.

1. Effects on the climate are commonly indicated as the *enhanced greenhouse effect* or *global warming*. Anticipating our discussion in Chapter 6, global warming is the term used to describe the phenomenon of the increasing global average temperature at the Earth's surface. Analysis shows that this temperature has increased by about  $0.6^{\circ}\text{C}$  in the last 100 years, taking full account of diurnal and seasonal temperature changes as well as for being averaged across the world in northern and southern hemispheres and over land and sea.

The atmosphere and the Earth receive energy through short-wave radiation by the Sun. At the same time, the Earth emits longer-wave, infrared radiation, of which the energy is partly absorbed by the molecules of atmospheric gases, such as water vapor  $\text{H}_2\text{O}$ , carbon dioxide  $\text{CO}_2$ , and ozone  $\text{O}_3$ . All the greenhouse gases are transparent to short-wave radiation, but partially opaque to long-wave radiation. Three or more atoms per molecule constitute the common property of greenhouse gases, with up to five atoms in the case of methane  $\text{CH}_4$ .

Like the action of the glass walls of a greenhouse (Figure 1.4-1), the heat

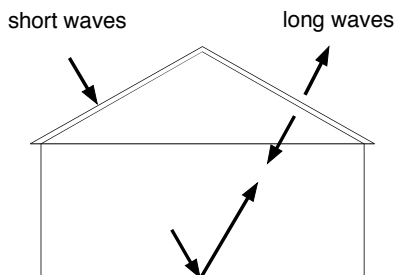

Figure 1.4-1. The greenhouse effect.

absorbed by a shield of greenhouse gases is re-emitted both upwards to space and downwards to the Earth's surface. Consequently, some of the heat that would otherwise be radiated into space is 'trapped' by these gases. As mentioned earlier, this phenomenon is known as the natural greenhouse effect. As long as the annual global energy radiated into space equals the solar energy absorbed by the Earth, there is a global equilibrium temperature on the Earth.

Especially, the increasing man-made production of carbon dioxide by burning fossil fuels and cutting down tropical rain forests cause a continuous increasing  $\text{CO}_2$  content in the atmosphere. Also enlarged concentrations of  $\text{H}_2\text{O}$ ,  $\text{NO}_x$ ,  $\text{CO}$ , UHC, and soot from burning fossil fuels disturb the thermal equilibrium condition of the Earth, and may lead to an enhanced greenhouse effect and so to an increase of the Earth's mean temperature. By  $\text{NO}_x$ ,  $\text{CO}$ , and UHC emissions the greenhouse gas ozone  $\text{O}_3$  is introduced in the atmosphere via secondary air pollution. This is the so-called tropospheric or 'bad' ozone, formed by photochemical reaction of oxygen  $\text{O}_2$  with nitrogen oxides, carbon monoxide, and unburned hydrocarbons.

The trapping of heat in the atmosphere may affect not only the Earth's surface temperature, but also weather conditions such as heavier rainfall, more serious floods, and greater numbers of thunderstorms and tornadoes.

For many coastal regions throughout the world the danger of storm surges may increase, especially in areas in which a rise in sea level and a greater risk of storms coincide.

2. A second issue of concern pertains to the occurrence of acid precipitation. Normal pure rainwater always has a slightly acid character because it takes up some of the atmospheric carbon dioxide and convert it into carbonic acid. Precipitation becomes an unnatural acidity by the presence of nitrogen oxides  $\text{NO}_x$  and sulfur dioxide  $\text{SO}_2$  as released into the air when burning fossil fuels. The oxides  $\text{NO}_x$  and  $\text{SO}_2$  readily combine with water vapor to form nitric and sulfuric acids. These acids then become condensation nuclei, thus producing acid precipitation. As soon as acid precipitation was detected, it was ascribed to anthropogenic pollution. It was found that, after evaporation, acid raindrops on plants and trees may leave behind high concentrations of acids, which may burn holes into the structure of the leaves. Evidently, acid precipitation may be harmful to forests and vegetation by accumulating acids in the soil. With high sulfur concentrations in the atmosphere, precipitation with sulfuric acid also can cause severe corrosion of mineral building materials. In recent years there has been an acceleration in damage of this type to old buildings and structures in city centers. Obviously, the only way to solve the problem is to stop or reduce the exhaust of harmful man-made products into the air.

3. Over the past twenty-five years, concern has grown over the effects of man-made chemicals on the ozone layer at very high altitudes in the stratosphere. Especially the introduction of chlorine and bromide compounds, and nitrous oxide  $N_2O$  into the atmosphere at ground level participates in the depletion of the ozone layer.

Also due to a transport of nitrogen oxides to larger heights when emitted by aircraft in cruise, air traffic may participate in the catalytic destruction of ozone through which the risk is increased that harmful solar ultraviolet radiation penetrates to the Earth's surface.

4. In addition, nitrogen oxides not only may cause the phenomenon of acidification, but also the formation of tropospheric ozone by a photochemical reaction with oxygen. In this way,  $NO_x$  may promote an enhancement of the greenhouse effect. Also, ozone is the photochemical precursor of the OH radical, one of the most important oxidants in the global atmosphere. In chemistry, a radical is a group of atoms that is replaceable in a molecule by a single atom and is capable of remaining unchanged during a series of reactions.

When in densely populated areas with high  $NO_x$  concentrations photochemical smog is formed, irritation of the eyes and mucous membranes may occur. Increased concentrations of ozone near ground level not only may have harmful effects on human beings but also can damage vegetation and forests, for instance by faster aging and poorer assimilation of nutrients and water.

5. Unburned hydrocarbons (UHC) as a result of incomplete combustion or insufficient mixing of fuel and air, carbon monoxide CO, and smoke (vapor made visible by the presence of tiny particles) have direct local effects in addition to those of ground level ozone, especially in urban environments. Acids from nitrogen oxides and sulfur dioxide can precipitate locally and damage vegetation or cause corrosion to buildings. Unburned hydrocarbons and soot particles are also detrimental to the living conditions of both humans and plants. Partial oxidation of the fuel may lead, via the separation of hydrogen atoms, to the formation of aromatic (e.g., benzene  $C_6H_6$ ) and polycyclic aromatic hydrocarbons (PAH). These substances can affect the body's DNA (deoxyribonucleic acid) and can cause cancer.

Local air pollution occurs mainly in a stable atmosphere, with little or no convective motions. Dispersion of pollutants hardly takes place, possibly leading to photochemical smog formation. This type of smog is formed when high concentrations of pollutants (smoke) are combined with fog. Automobile emissions of UHC,  $NO_x$  and VOC (volatile organic compounds), such as benzene and toluene may lead, under the influence of ultraviolet solar

radiation, to the formation of ozone  $O_3$  at ground level. Ozone is a strongly oxidative and poisonous gas.

A summary of the various harmful effects of combustion emissions is given in Table 1.4-1.

Without doubt, the troposphere is of tremendous significance for the generation and dispersion of pollutant substances. In particular, the lowest 2000 meters of the atmosphere are of significance to accomplish the desired dispersion and dilution of air pollutants. Within this layer the horizontal and vertical motions of the air greatly affect the way in which pollutant substances disperse, and to what degree the atmosphere is self-cleaning.

A measure to reduce anthropogenic pollution near the ground from heavy industry is the use of high smoke stacks. In residential areas, the improvement of smoke disposal from domestic chimneys is an effective measure.

The replacement of coal by natural gas for heating and power generation purposes, and equipping motor vehicles with catalytic converters have also proven to be effective. Flue gases from installations using natural gas as a fuel contain relatively low amounts of sulfur dioxide  $SO_2$  compared to the use of sulfurous coal.

Pollutant	Effects on environment	Effect on health
CO	Tropospheric ozone production	Toxic
UHC	Global warming Tropospheric ozone production Smog	Toxic
Smoke	Global warming	Respiratory problems Cancer
SO <sub>x</sub>	Global warming Corrosive Acid rain	Toxic
NO <sub>x</sub>	Global warming Tropospheric ozone production Tropospheric ozone depletion Smog Acid rain	Toxic
CO <sub>2</sub>	Global warming	
H <sub>2</sub> O	Global warming	

Table 1.4-1. Harmful effects caused by combustion emission.

## 1.5 MOTOR VEHICLE EMISSIONS

Worldwide, the transport sector accounts for about 30 percent of the global energy consumption, almost all of which comes from oil-derived products. Ground transport (road and rail) is responsible for about 85 percent of the total energy use in the transport sector. Therefore, the transport sector is a major contributor to greenhouse gases as it produces about 18 percent of all carbon dioxide released from fossil fuels (Ref. 3).

In addition, ground transport generates a large percentage of anthropogenic carbon monoxide (CO) emissions, unburned hydrocarbons (UHC), soot (particulate matter), nitrogen oxides ( $\text{NO}_x$ ), and sulfur oxides ( $\text{SO}_x$ ). Accordingly, road traffic contributes also to the acidification of the environment, and the formation of photochemical smog. Therefore, in confined places and congested streets, emission pollutants from ground transport may rise to levels that are hazardous to health.

At stoichiometric (ideal) combustion conditions, the combustion process consumes approximately 15 kg of air per kg of fuel, to form the combustion products carbon dioxide  $\text{CO}_2$  and water  $\text{H}_2\text{O}$ . If the sulfur contained in the fuel is burned completely, sulfur dioxide is produced.

The propulsion of motor vehicles generally involves combustion processes with less favorable fuel to air ratios, and insufficient mixing of fuel and air. Furthermore, the process often takes place too fast at a relative (too) low temperature. Consequently, pollutants will be formed.

Carbon monoxide CO is the intermediate product in the combustion process of carbon to carbon dioxide  $\text{CO}_2$ . If there is a lack of air or the combustion temperature and residence time in the flame are insufficient, part of the CO can escape along with the exhaust gases. If the hydrocarbons are not fully oxidized during combustion, in the combustor a decomposition process takes place, leading to the formation of new hydrocarbons via the separation of hydrogen atoms. In this way substances like aromatic and polycyclic aromatic hydrocarbons (PAH's) are formed, which also are emitted along with the exhaust plumes.

The formation of soot (carbon-containing particles) results from the application of high flame temperatures and from incomplete combustion due to lack of oxygen  $\text{O}_2$ . Also nitrogen oxides  $\text{NO}_x$  are formed during combustion processes with high flame temperatures through oxidation of the nitrogen  $\text{N}_2$  in the air and through the combustion of the fuel-bound nitrogen. Primarily, nitrogen monoxide NO is produced, whereas nitrogen dioxide  $\text{NO}_2$  is formed only after

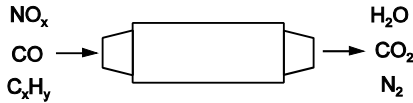
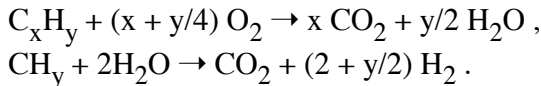

Figure 1.5-1. Motor vehicle catalytic converter.

the combustion when there is a sufficient oxygen content in the exhaust gases and finally in the atmosphere.

A feasible measure to reduce pollutant emissions from motorized vehicles is the use of a *three-way catalytic converter* (Figure 1.5-1). The term “three-way” indicates that the three pollutants UHC, CO, and  $\text{NO}_x$  are transformed, via the following gross reactions (Ref. 5):

1. Transformation of hydrocarbon:



2. Transformation of carbon monoxide:

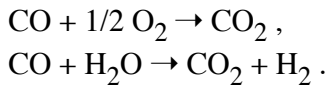

3. Transformation of nitrogen oxides and unburned hydrocarbons:

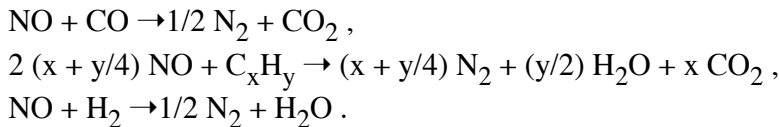

The body of the catalytic converter is placed in the engine exhaust pipe before the muffler. It should be noted that after disposal, the catalytic converter will have to be processed as well.

With the state of the art technology, the catalytic converter is only applicable to gasoline-powered and diesel-powered piston engines. Although diesel-powered vehicles emit lower amounts of carbon monoxide and unburned hydrocarbons than gasoline-powered vehicles, their emission of carbon particulates is considerably higher.

fuel	heating value, J/kg
hydrogen	$11.85 \times 10^7$
methane	$4.89 \times 10^7$
kerosene	$4.34 \times 10^7$
coal	$3.30 \times 10^7$
natural gas	$3.16 \times 10^7$
brown coal (lignite)	$2.70 \times 10^7$
fire wood	$9.83 \times 10^6$

For remarks regarding the determination of the heating value, the reader is referred to Chapter 10, Section 10.3.

Table 1.5-1. Heating value of various fuels.

Other measures to reduce air pollution from road traffic are:

1. The utilization of unleaded petrol. However, to accomplish a better knock-resistance, aromatic compounds such as benzene are to be used as a fuel additive.
2. Speed reduction, i.e., a reduction of the combustion temperature.
3. The development of *clean* fuels and economic engines. Economic engines involve adequate combustion and a high thermal efficiency  $\eta_{th}$ , which is defined by:

$$\eta_{th} = \frac{P_{br}}{m_f H}, \quad (1.5-1)$$

where  $P_{br}$  is the power delivered to the shaft,  $m_f$  the fuel mass flow rate and  $H$  the *heating value* or *heat of combustion* of the fuel. For gasoline,  $H \approx 4.3 \times 10^7$  J/kg (Table 1.5-1). The thermal efficiency of current piston engines, approximately, amounts to 30%.

## 1.6 AERO-ENGINE EMISSIONS

As shown in Figure 1.6-1, in an ideal (stoichiometric) combustion process, carbon dioxide  $\text{CO}_2$  and water  $\text{H}_2\text{O}$  are formed as combustion products. Unfortunately, ideal combustion processes do not exist and also undesirable compounds are formed, mainly consisting of nitrogen oxides  $\text{NO}_x$ , carbon monoxide  $\text{CO}$ , unburned hydrocarbons (UHC), sulfur oxides  $\text{SO}_x$ , and soot

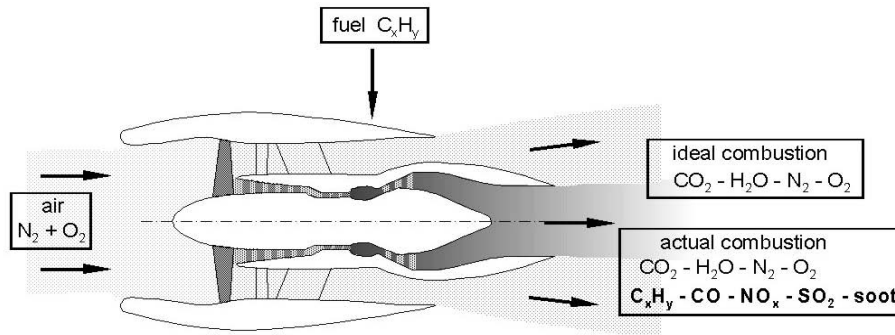

Figure 1.6-1. The combustion process in a turbofan engine.

particles. At present there is only a limited knowledge about the formation and behavior of minor, trace species and aerosols found in the exhaust gases of turbo-engines. Even less is known about how they are influenced by engine features and characteristics (Ref. 1).

Emissions of  $NO_x$ , CO, and UHC can be reduced by improved combustion techniques, while reduction of  $CO_2$  and water  $H_2O$  requires reduced fuel consumption. A favorable feature of the kerosene fuel used for jet airplane propulsion is that it contains almost no sulfur. Therefore, the emission of sulfur dioxide  $SO_2$  by airplanes is very low and usually negligible.

Although air transport uses just 5 percent of the global oil consumption per year and about 13 percent of the yearly consumption of fossil fuels taken by all forms of transport, control of pollutant emissions from the combustion of kerosene is of increasing importance in the design and operation of airplanes and airplane propulsion systems.

This is reflected by the fact that already for many years, standards for the pollutants produced by aviation engines, namely carbon monoxide CO, unburned hydrocarbons (UHC), nitrogen oxides  $NO_x$ , and smoke, are set by the International Civil Aviation Organization (ICAO) in Ref. 6. According to its definition by ICAO, smoke is formed by the carbonaceous materials in exhaust emissions which obscure the transmission of light.

In the past, man was merely concerned with the effects of pollutant emissions at ground level near the airports. In this respect, with success, attention has been given to the reduction of CO and UHC, which appear to be dominating at low thrust settings of the engine (Figure 1.6-2). Smoke emissions, which used to dominate at high thrust settings, have also been greatly reduced.

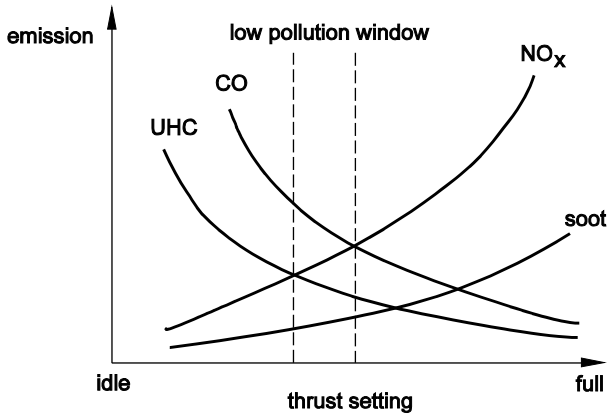

Figure 1.6-2. Emission level versus thrust setting.

Presently, much effort is devoted to the effects of emissions from aircraft upon the upper region of the troposphere and the lower region of the stratosphere, since at these heights the airplane is the only anthropogenic source of pollutants. Especially, the emissions of NO<sub>x</sub>, the result of burning kerosine at high temperatures, have been increased during the past decades.

For long-range flights, naturally, the largest amount of NO<sub>x</sub> will be emitted during the cruise part of the flight, where is flown at altitudes near the tropopause.

Today, therefore, considerable effort is being made to lower the NO<sub>x</sub> emissions by improving the combustion process. Also, reducing the fuel consumption per flight will remain an effective way of decreasing the impact of aviation on the environment.

## 1.7 THE HYDROLOGICAL CYCLE

A great influence on the removal of pollutants from the atmosphere has the *hydrological cycle* by which water evaporates from oceans and land, is transported by air motions, forming clouds and precipitations, and returns from oceans and land to the atmosphere (Figure 1.7-1).

Wind blowing across the oceans and wave action produce a fine spray of water droplets containing salt. Upon these solid particles the water vapor in the atmosphere may condense.

Figure 1.7-2 illustrates the general, global pressure and surface wind

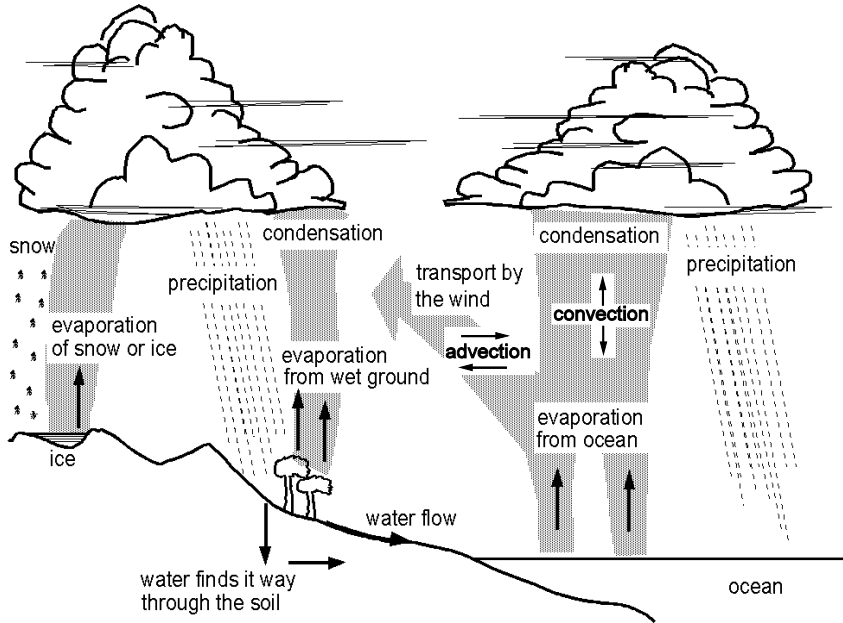

Figure 1.7-1. The hydrological cycle.

distributions. Surface winds are defined as winds occurring at very low heights. Close to the Equator the surface water, and so the air in contact with it, is heated intensively by its direct exposure to solar radiation. The warming of air produces a region of low atmospheric pressure into which air is drawn.

The low pressures near the Equator are the source of the well-known *trade winds*. Mariners exploited these winds, but dreaded the equatorial belt of light variable winds lying between them, which they called the *doldrums*.

In the mid-latitudes the familiar westerly winds (*westerlies*) prevail, while in both polar regions easterly winds (*easterlies*) occur.

Note that the direction of the wind is that direction from which it is blowing. If the wind is coming from the southwest, its direction is said to be southwest (S.W.). Usually wind directions are reported by directions on a 32 points compass or in degree (Figure 1.7-3). Thus, at the northern hemisphere the direction of the trade wind is N.E. (northeast) and at the southern hemisphere S.E. (southeast).

Like wind, also oceans and seas are important to the dispersion of heat energy over the Earth. Oceans and seas cover more than 70 percent of the total surface of the Earth. The average depth is 3.73 km and together they contain 1370 million km<sup>3</sup> of water. If the Earth would be covered by one vast ocean, the ocean would be 2.7 km deep.

The trade winds drive the surface currents toward the Equator, through which

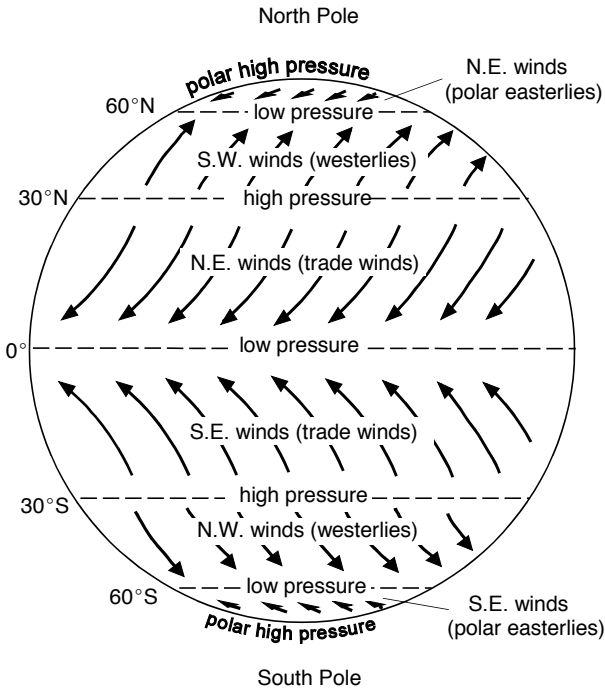

Figure 1.7-2. Global surface pressures and air currents.

cold water is heated and returns to warm the higher latitudes from which it came. Clearly, the transport of cool water to the Equator prevents the tropical regions from being as hot as they would be otherwise.

The atmosphere is warmed from underneath through which convection may ensue, with vertical ascents and descents of air, leading to a thorough mixing of the air. This situation is opposite to that at the surfaces of the oceans, where the water is heated from above by the Sun. This implies that there are layers of

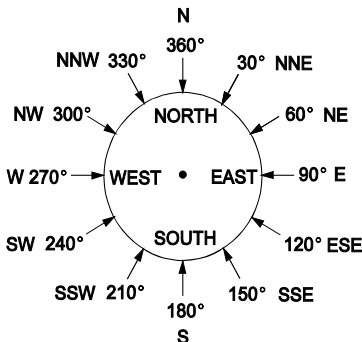

Figure 1.7-3. Wind direction scales.

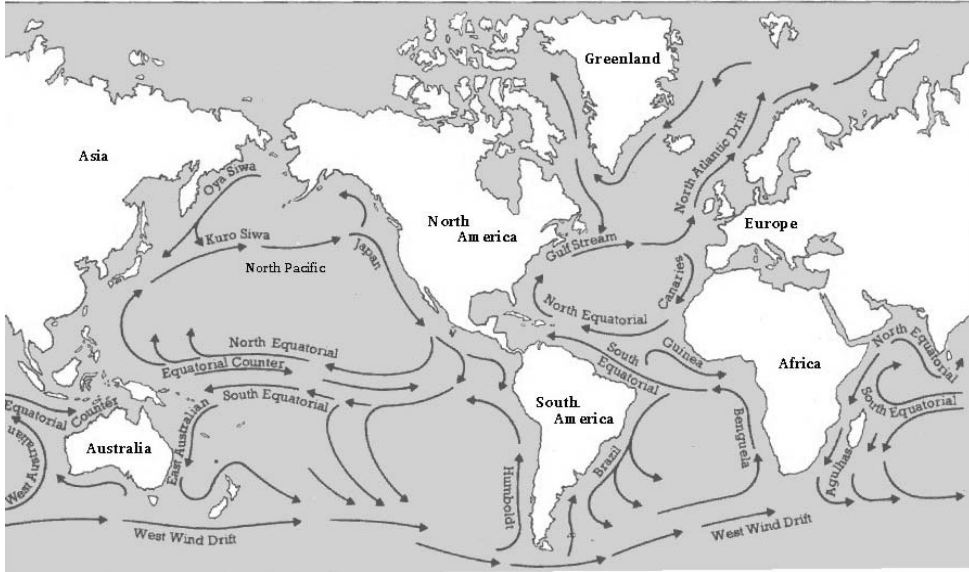

Figure 1.7-4. Major ocean currents.

relatively warm water floating above cooler and denser water masses. As little vertical mixing occurs, the oceans can be divided into approximately horizontal layers with different water temperatures.

At the same time, the water in the oceans is in constant horizontal motion. Friction between the water and the moving air keeps the water flowing in the direction of the wind. The interaction between wind and water has created the major global currents, which brings warm tropical water to the higher latitudes.

Figure 1.7-4 shows great surface motions of the oceans and seas, as caused by the prevailing surface winds. Due to the *Coriolis force*, which bends winds because of the rotation of the Earth about its own axis, also the flow of water is deflected toward the right north of the Equator and toward the left south of it (see also Chapter 2, Section 2.6). Summarizing, it may be said that by carrying warm water to cool latitudes, and cool water to warm latitudes, the ocean currents have a major effect on the local weather and the climates of the world's regions.

In addition to the surface winds, the influence of tidal currents, as caused by the combined effect of the gravitational pull of the Earth, Moon and Sun upon the water mass on the Earth, is of importance to the transfer of heat over the Earth. The essentials of *ebb and flow* of the *tides* are discussed separately in the next section.

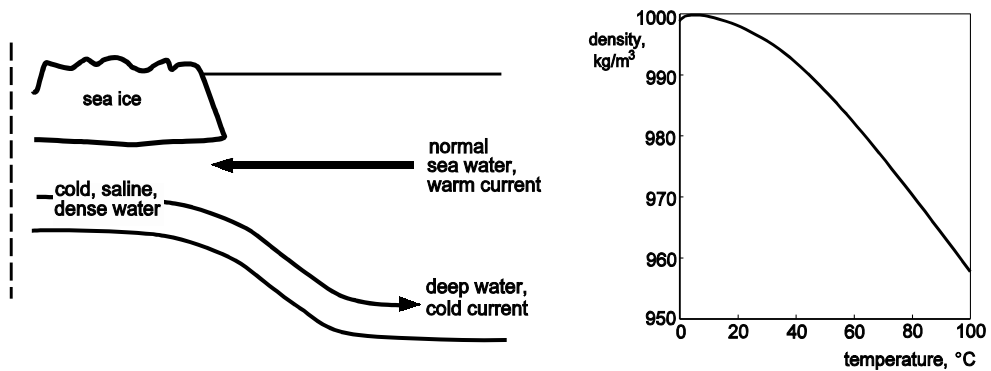

Figure 1.7-5. Formation of deep water current. Figure 1.7-6. Density of water.

Besides the movement of surface water, there are the deepwater currents (Figure 1.7-5). These are flowing from the polar regions, mainly by the formation of sea ice, which removes fresh (saltless) water from the sea surface.

Immediately below the sea ice, the water is therefore more saline. Moreover, the water has a temperature at which it has approximately its greatest density (Figure 1.7-6). These factors make the surface water more dense than the water below it. Accordingly, the water sinks below the less denser water and, at the same time, moves away from the sea ice. In this way a flow is established of very cold, saline water moving away from the Poles along the bottom of the ocean toward the Equator. Its place is taken by water flowing polewards beneath the surface water, and then is forced to rise as it encounters the denser water that is sinking. The above mechanisms are believed to drive the oceanic system of heat transport by ocean currents.

To conclude, it is important to emphasize that pollution not only implies the release of undesired substances into the atmosphere and soil, but also their introduction into the water. In this respect it should be noted that the oceans also are of great importance to the environment and the climate in the sense that they provide yearly the storage of an enormous amount of carbon dioxide from the atmosphere. The  $\text{CO}_2$  leaving the atmosphere dissolves in the upper layers of the oceans and seas and, finally, becomes mixed into the deeper layers. Concerning this storage, it is worthy of mention that, as with oxygen, the solubility of water decreases as its temperature rises. In plain words, warm water cannot contain as much carbon dioxide as cool water.

Another consequence of a rise in the global average temperature at the Earth's surface, is that the waters of the oceans will warm and expand. Moreover, their volumes will increase as polar glaciers and other large land ice caps melt. This

would lead to a rise in sea level all over the world, and drown the land of low-lying countries and islands.

A temperature rise also will lead to increased evaporation and, therefore, to increased precipitation.

## 1.8 TIDAL CURRENTS

Tidal currents from the periodic rise and fall of the oceans are created by the combined gravitational action of the Earth, Sun and mainly the Moon upon the water mass on the Earth.

Figure 1.8-1 shows the orbital motions in the Sun-Earth-Moon system. Within this system, the Earth and Moon form a single system, mutually rotating around their common center of mass. The Earth-Moon barycenter is inside the Earth, about 1700 km below the surface (Figure 1.8-2).

Assuming circular orbits, the angular velocities and the radii of the paths traveled are the same everywhere. As a result of the eccentric motion, all points on and within the Earth will experience an equal centrifugal force. These forces are directed parallel to a line joining the centers of the Earth and the Moon.

On the contrary, the gravitational force exerted by the Moon on the Earth varies inversely with the square of the distance from the Moon. Points on the Earth nearest the Moon will experience a greater gravitational pull from the Moon than will points on the opposite side of the Earth. Because the component parts of the gravitational force are directed toward the Moon's center, the forces will not be exactly parallel to the direction of the centrifugal forces, except the force directed along the line joining the centers of the Earth and Moon.

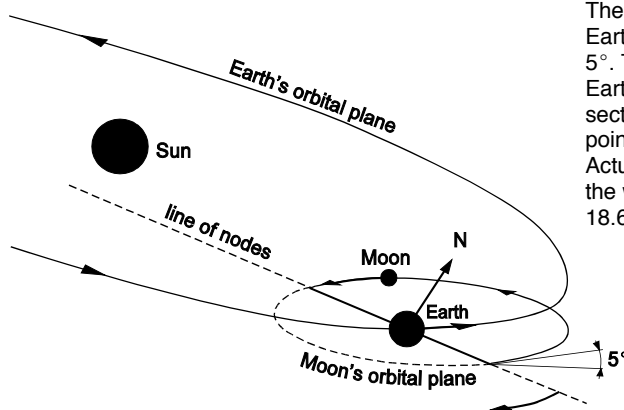

The Moon's orbital plane intersects the Earth's orbital plane at an angle of about  $5^\circ$ . The two planes are ellipses. As the Earth revolves around the Sun, the intersection line (*line of nodes*) continues to point in a fixed direction among the stars. Actually, the line of nodes rotates toward the west and completes a revolution in 18.6 years.

Figure 1.8.1. The orbital motions in the Sun-Earth-Moon system.

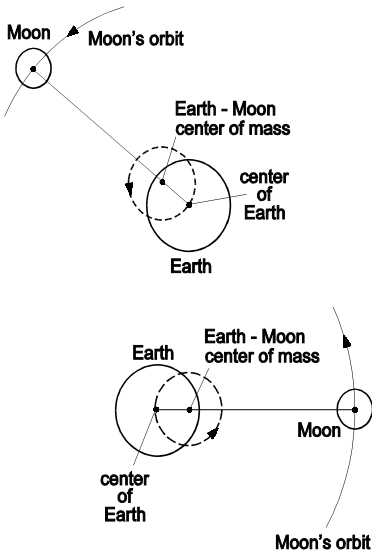

Figure 1.8-2. The rotation of Earth and Moon about the center of mass of the Earth-Moon system.

However, the total centrifugal force within the Earth-Moon system exactly balances the total force of gravitational attraction between the two bodies, so that the system as a whole is in equilibrium.

The resultant of the two forces at each point on the Earth's surface is known as the *tide-producing force*, and, depending upon its position on the Earth's surface with respect to the Moon, will be directed into, away from, or parallel to the

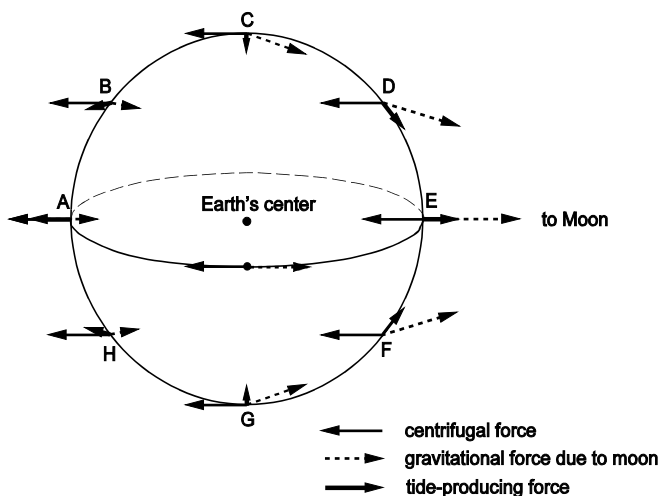

Figure 1.8-3. Tide-producing forces (not to scale).

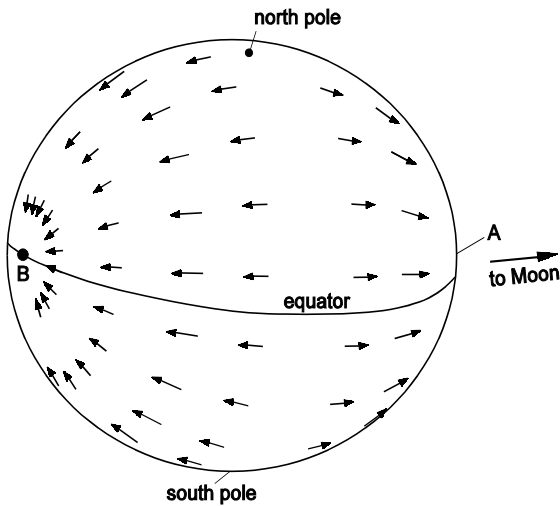

Figure 1.8-4. Tractive forces.

Earth's surface. The relative strengths and directions of the forces are illustrated in Figure 1.8-3.

Obviously, at points A and E in Figure 1.8-3 the difference between the centrifugal force and the Moon's gravitational force is greatest. Nevertheless, the local effects of these forces on ebb and flow of the tides are negligible as they are acting against the pull of the Earth's own gravity, which strongly exceeds the resulting tide-producing force.

At other points the effects of the tide-producing forces are well perceptible when there is a large horizontal component of this force. These so-called *tractive forces* cause the water to move, because, although small compared with the Earth's gravitational field, this horizontal component is not opposed by any other lateral force.

Figure 1.8-4 portrays where on the Earth's surface the tractive forces are at a maximum when the Moon is over the Equator. In this special situation, the tractive forces would result in a movement of water toward points A and B, producing an ellipsoid with its two bulges directed toward and away from the Moon (Figure 1.8-5a).

Because the Moon rotates about the Earth-Moon center of mass once every 27.3 days in the same direction as the Earth rotates upon its *polar axis* once every 24 hours, the period of the Earth's rotation with respect to the Moon is about 24 hours and 50 minutes (a *lunar day*), so that the lunar semi diurnal tide has a period of 12 hours and 25 minutes (Figure 1.8-6). Clearly, the times of high tides at many locations are almost an hour later each successive day.

Variations in the lunar-induced tides occur due to fact that the relative positions and orientations of the Earth and Moon vary according to the Moon's

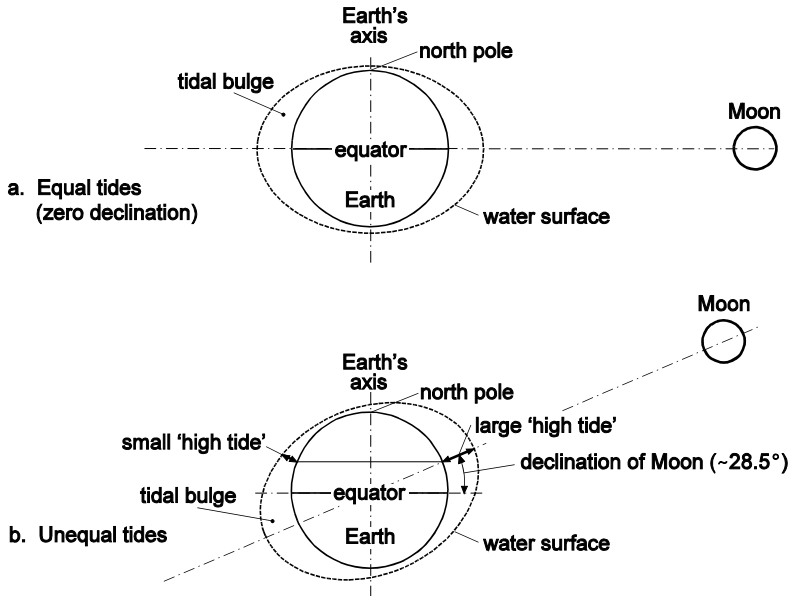

Figure 1.8-5. Effect of Moon's declination.

declination. As shown in Figure 1.8-5b, the Moon's orbital plane is inclined at an angle of  $28.5^\circ$  relative to the plane of the Earth's Equator. Consequently, when the Moon is at a large angle of declination, particularly, at mid-latitudes unequal tides will be produced. Hence, the heights reached by the two daily tides will show diurnal inequalities.

Moreover, the elliptical orbit of the Moon around the Earth-Moon center of mass results in variations in the tide-producing forces. When the Moon is closest to the Earth, the tide-producing force is increased above the average value, and decreased when the Moon is furthest from Earth.

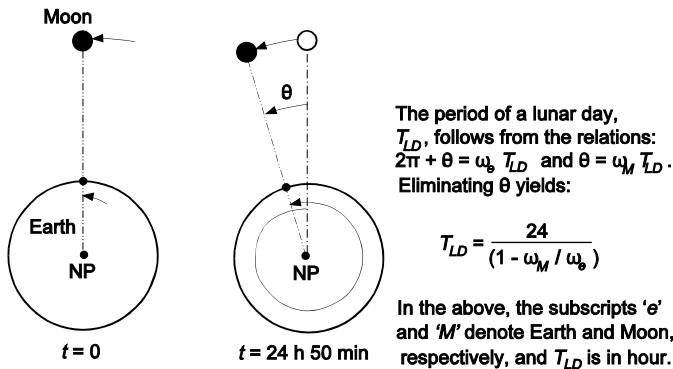

Figure 1.8-6. Solar and lunar day relationship.

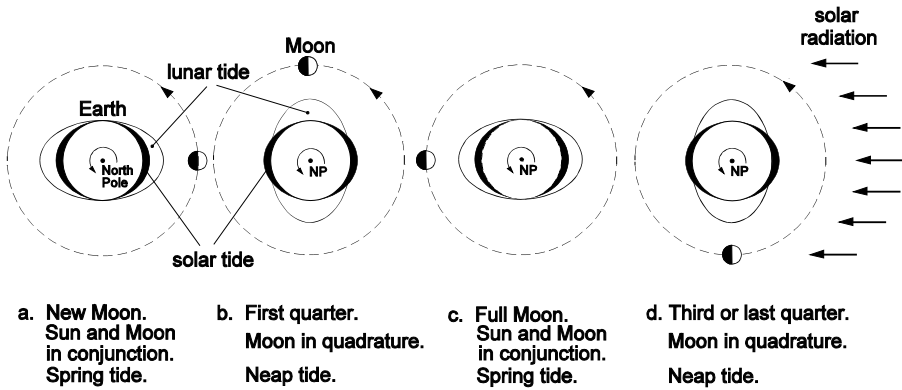

Figure 1.8-7. Interaction of lunar and solar tides.

Tides are highest when the Moon is full or new, and the times of high tide at any given location can be approximately related to the position of the Moon in the sky. The Sun also causes a tide-producing force, of which the magnitude is much smaller than that of the Moon, because, although enormously greater in mass than the Moon, the Sun is some 360 times further from the Earth. The resulting effect depends on the position of the Earth, Sun and Moon together, whether their position is in line or not. Figure 1.8-7 shows the simplest case, where the declinations of Moon and Sun are both zero.

When the tide-generating forces of the Sun and Moon are acting in conjunction, the high tide is higher and the low tide is lower than the average. Such tides are known as *spring tides* (Figures 1.8-7a and c). On the other hand, when the Sun and Moon act at right angles to each other, the tidal range is correspondingly smaller than average. These tides are known as *neap tides* (Figures 1.8-7b and d).

Of course, the force fields outlined above are strongly simplified. The regular changes in the declination of the Sun and Moon, and the elliptical orbits of the Earth around the Sun and the Moon around the Earth, will affect the tide at any particular time and place. Furthermore, the effects of topography, wind and atmospheric pressure distribution are also of significance. For practical use, tide-tables are available, indicating times of ebb and flow, and water levels. For further information and the theory on the dynamics of the tides, the reader may turn to Ref. 7.

## 1.9 THE SI-SYSTEM OF UNITS

Throughout this book the *International System of Units* (officially called *Système International d'Unités* in French) is used. This metric system has been adopted by many nations as the recommended system of units for weights and measures. In Table 1.9-1 are tabulated the seven basic SI units, and derived units that are relevant to this text.

It is of interest to note that, despite the legal adoption of the SI system of units, in engineering practice frequently the so-called *technical system of units* is used. In this system the quantity force, having also the name kilogram, is a basic unit instead of mass. In order to distinct these two kilograms, in the technical system the quantity force is (often) denoted as kilogram force, abbreviated as kgf. The following relationship is defined:

$$1 \text{ kgf} = 9.80665 \text{ N.}$$

quantity	name of unit	symbol	definition
<b>basic SI-units</b>			
length	meter	m	
mass	kilogram	kg	
time	second	s	
temperature	kelvin	K	
electric current	ampère	A	
luminous intensity	candela	cd	
amount of substance	mole	mol	
<b>derived SI-units</b>			
force	newton	N	$\text{kg m/s}^2$
pressure	pascal	Pa	$\text{N/m}^2$
work (energy)	joule	J	$\text{J} = \text{N m}$
power	watt	W	J/s
velocity	meter per second	V	m/s
acceleration	meter per second squared	a	$\text{m/s}^2$
density	kilogram per unit cubic meter	$\rho$	$\text{kg/m}^3$

Table 1.9-1. Basic and derived SI- units.

Also note that the technical system may also be expressed in English units, using foot (ft) and pound force (lbf) as basic units for length and force, respectively. The following relationships are defined:

$$1 \text{ ft} = 0.3048 \text{ m},$$

$$1 \text{ lbf} = 0.45359 \text{ kgf} = 4.44822 \text{ N}.$$

A number of technical units and corresponding SI units are given in Table 1.9-2. Although the SI unit of temperature is the kelvin (K), also the celsius or centigrade scale is employed. Since the unit degree celsius ( $^{\circ}\text{C}$ ) is exactly equal to the unit kelvin, temperature expressed in degree celsius can be readily converted to temperature in kelvin by the relationship:

$$^{\circ}\text{C} = \text{K} - 273.15.$$

In nonscientific usage one may use the temperature scale fahrenheit. To convert degree celsius to degree fahrenheit ( $^{\circ}\text{F}$ ): multiply by  $9/5$  and add 32,

$$^{\circ}\text{F} = ^{\circ}\text{C} \times 9/5 + 32.$$

Similarly, to convert degree fahrenheit to degree celsius: subtract 32 and multiply by  $5/9$ .

quantity	technical system		SI - system
	metric	English	
length	m	ft	m
time	s	s	s
force	kgf	lbf	$\text{kg m/s}^2$ (newton)
mass	$\text{kgf s}^2/\text{m}$	$\text{lbf s}^2/\text{ft}$ (slug)	kg
pressure	$\text{kgf/m}^2$	$\text{lbf/ft}^2$	$\text{N/m}^2$
work (energy)	kgf m	lbf ft	$\text{kg m}^2/\text{s}^2 = \text{N m}$ (joule)
power	kgf m/s	lbf ft/s	$\text{kg m}^2/\text{s}^3 = \text{J/s}$ (watt)
density	$\text{kgf s}^2/\text{m}^4$	$\text{lbf s}^2/\text{ft}^4$	$\text{kg/m}^3$

Table 1.9-2. System of units.

### 1.10 POLLUTANT CONCENTRATION

Naturally, the degree of harmfulness is different for the various pollutants. That’s why central to the concept of air pollution is the concentration, since there is no substance so dangerous that there is no dose below which it is harmless to all organisms.

Important to the quantification of air pollution is the fact that atmospheric properties mostly involve large quantities, whereas pollution usually concerns very small concentrations.

Table 1.10-1 presents the prefixes, frequently used to avoid extremely large or small numbers.

When referring to trace gases, usually, the concentration is expressed in terms of ppm (parts per million,  $10^6$ ), ppb (parts per billion,  $10^9$ ), or ppt (parts per trillion,  $10^{12}$ ). These units indicate that the pollution particles differ from the other million, billion or trillion particles in the sample.

A distinction may be made by noting: ppm (v) for ‘parts per unit volume’ ( $\text{ml}/\text{m}^3$ ) and ppm (m) for ‘parts per unit mass’ ( $\text{mg}/\text{kg}$ ). Also, the ratio  $\text{mg}/\text{m}^3$  may be used.

Finally, it should be noted that the denomination of some large numbers has different meanings in the USA and European countries (Table 1.10-2).

multiple	prefix	symbol	fraction	prefix	symbol
$10^{24}$	yotta	Y	$10^{-1}$	deci	d
$10^{21}$	zetta	Z	$10^{-2}$	centi	c
$10^{18}$	exa	E	$10^{-3}$	milli	m
$10^{15}$	peta	P	$10^{-6}$	micro	$\mu$
$10^{12}$	tera	T	$10^{-9}$	nano	n
$10^9$	giga	G	$10^{-12}$	pico	p
$10^6$	mega	M	$10^{-15}$	femto	f
$10^3$	kilo	k	$10^{-18}$	atto	a
$10^2$	hecto	h	$10^{-21}$	zepto	z
10	deca	da	$10^{-24}$	yocto	y

Table 1.10-1. Standard multiples and decimal fractions.

number	denominator	
	European	American
$10^6$	million	million
$10^9$	milliard	billion
$10^{12}$	billion	trillion
$10^{15}$	thousand billion	quadrillion
$10^{18}$	trillion	quintillion
$10^{21}$	quadrillion	septillion
$10^{30}$	quintillion	nonillion

Table 1.10-2. Denomination of numbers.