

The pictures in this pdf file  
have been reduced to 72 dpi

# 10 DIMENSIONS



Dice blocks on breakwater Hook of Holland (courtesy Rijkswaterstaat)

## 10.1 General

In the previous chapters, many relations between load and strength have been presented. This chapter focuses on how to deal with the variations in loads as encountered in nature and with the strengths of structures which also show variations and which decreases after construction. Maintenance and repair are therefore important to maintain the strength of a structure in time.

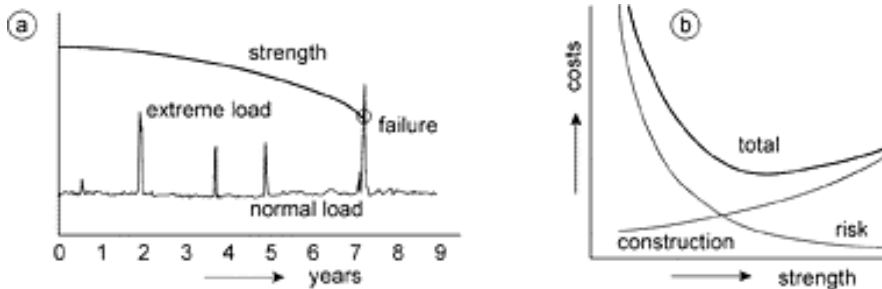

Figure 10-1 Failure, risk and costs

Figure 10-1a shows the eventual destiny of any structure without maintenance. The strength decreases due to wear and tear, erosion or fatigue. The load has a random nature and there is a probability that, at some moment, the load will exceed the strength and that the structure will collapse, crack or fail. Figure 10-1b shows the idea behind an economic design: a very strong structure runs little risk of failure but is expensive, while a less strong structure is cheaper but the risk is high. Somewhere in between, there is an optimum. Although very logical and simple, it is hard to quantify this into workable numbers.

The risk of failure can be expressed in general terms:

$$\text{Risk} = \text{probability} * \text{consequence} \quad (10.1)$$

in which the probability (a number between 0 and 1) can be expressed as probability per year and the consequence can be expressed as loss of money and/or human lives, hence the unit of risk is loss per year. To keep the risk acceptably low, an event with a large consequence should have a low probability. Section 10.2 gives more details.

The consequence is related to the choice of the limit state in the failure analysis. As already said in chapter 1, a distinction is made between the Serviceability Limit State (SLS) and the Ultimate Limit State (ULS). The ULS defines collapse or such deformation that the structure as a whole can no longer perform its main task. It is usually related to extreme load conditions. The SLS defines a partly or temporarily unusable state of structure. In the case of a harbour, the SLS could represent such wave penetration that transshipment of goods is impossible, while the ULS could be the collapse of a breakwater. The choice of the SLS is less clear e.g. for a bottom or

dike protection. In Vrijling et al.,1992, the SLS is seen as the deterioration of strength under persistent loads. In the light of equation (10.1) it is obvious that the probability of reaching a ULS should be much lower than reaching an SLS. In the example of the harbour  $P_{SLS} = 1/\text{year}$  and  $P_{ULS} = 0.01/\text{year}$ . Section 10.3 goes into more details concerning maintenance policies and the relation between the SLS and maintenance.

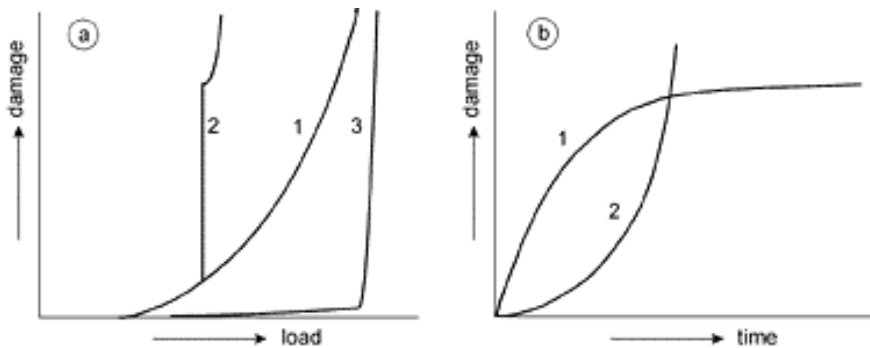

Figure 10-2 Differences in structural behaviour

When an acceptable probability needs to be determined, the behaviour of the structure and the material is important. Figure 10-2a shows the damage as a function of load, given a certain loading period. Line 1 represents the "normal" behaviour of rock under waves or flow. Line 2 is valid for a relatively thin layer of the same rock with a filter layer of much finer material underneath. Besides removal of the top layer, this leads to a large increase of damage and further deterioration depending on what is behind the filter. Line 3 may hold for a block revetment with clamping forces. Up to a certain load, the blocks are lifted somewhat, but there is no real damage. Beyond a certain level, the load causes a sudden instability and a complete row of blocks can be removed.

Figure 10-2b is similar to Figure 10-2a, but shows the damage as a function of time given a certain load. Line 1 is the behaviour found for rock under waves or current. In the Van der Meer formulas, the number of waves influences on the damage ( $S \propto \sqrt{N}$ ) more or less according to line 1. In the Van der Meer relations, the number of waves is limited to a maximum of 7000 since in experiments the damage hardly increases beyond that number. Line 2 may be valid for an asphalt revetment which is lifted by water pressure. After some time, due to the plastic behaviour of asphalt, the deformation suddenly increases and even rupture of the material is possible.

In a probabilistic analysis, some of the above-mentioned properties can be included in the distributions of strength and load. In many cases, however, these peculiarities are handled with "engineering judgment", a strange mixture of experience, common sense and intuition, often leading to keeping a safe margin. A designer must always

foresee the consequences of a failure. Thinking about failure mechanisms is therefore important, as will be treated in Section 10.4.

## 10.2 Probabilistics

### 10.2.1 Introduction

It is impossible or uneconomical to make a structure so strong that it will never fail. A hydraulic engineer's task is therefore to design structures with an acceptable risk of failure. In terms of load and strength, this means that the probability that the load exceeds the strength should remain below a certain value. This value depends on the consequences, see again equation (10.1). It is possible to express load and strength in a limit state function  $Z$ :

$$Z = \text{Strength} - \text{Load} = R - S = R(x_1, x_2, \dots, x_m) - S(x_{m+1}, \dots, x_n) \tag{10.2}$$

where  $R$  is the strength and  $S$  the load and  $x_1 \dots x_m \dots x_n$  represent all random variables involved in strength and load (like wave height, wave period, stone diameter, slope angle etc.).  $S$  as a symbol for load and not for strength does not seem logical, but this is according to international agreement.  $R$  and  $S$  are acronyms related to the French words *Résistance* and *Sollicitation* ("asking"). We will stay in line with this agreement, despite the confusion at first glance.

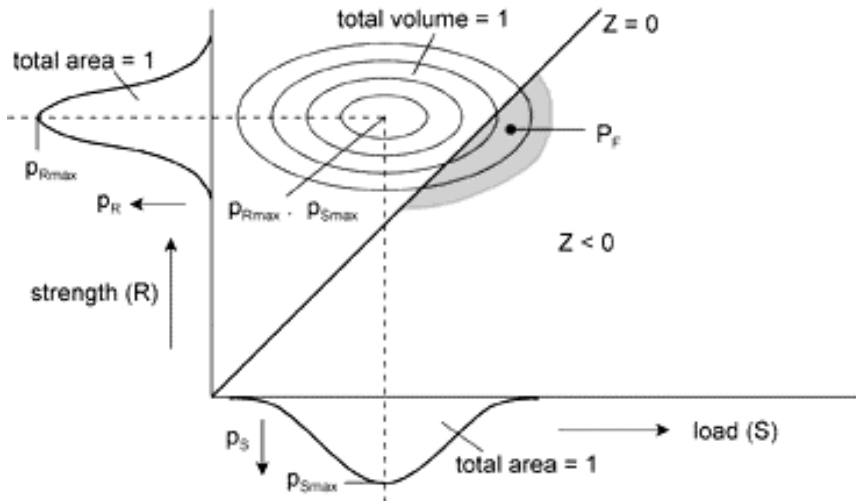

Figure 10-3 Probability mountain

Figure 10-3 gives the probability density distributions of load and strength ( $p_S$  and  $p_R$ , respectively). When  $R = S$  ( $Z = 0$ ), the structure (or part of it, depending on the scope of  $Z$ ) reaches the limit state as defined with  $Z$ . A three-dimensional representation of

the probability distributions is most appropriate, as, theoretically, for every load  $S$  there is a  $R < S$  and, the other way around, for every strength  $R$  there is a  $S > R$ . So, the combination of probabilities of  $Z < 0$  determines the total probability of failure:

$P_F$ .

$P_F$  is the volume of the part of the "probability mountain" (of which the contour lines have been drawn in the figure) where  $Z < 0$ . This volume is given by:

$$P_F = P(Z < 0) = \iiint_{Z(x) < 0} \dots \int p_{\underline{x}}(x) dx_1 \dots dx_n \quad (10.3)$$

where  $x_1 \dots x_n$  again represent all parameters involved. Every parameter has its own probability distribution and the determination of  $P_F$  can lead to very complex and labour-intensive computations. Finding reliable probability functions for every parameter is also a difficult and time consuming process.

#### Intermezzo 10-1

##### ***Some history***

Dikes in The Netherlands are much older than probabilistic design methods. The height of a dike was always related to the "highest water level ever", the locally registered maximum water level in history. Whenever the maximum registered water level was exceeded a new "highest water level ever" could be defined. This went on for many centuries and people lived with these ways of life. In a modern society, where man tries to minimize risks, this is highly unsatisfactory. In 1939 the knowledge of statistics led to the awareness that higher water levels would always be possible, but with a lower probability (see Wemelsfelder, 1939).

However, it took another disaster in 1953 to affect decision making. No maximum wind velocity or rainfall is known in nature, hence, there is no maximum water level due to storm surges or river discharges either. A probabilistic approach is the only way to deal with loads in nature. In structural engineering the situation is somewhat different. The maximum load on a bridge can be influenced by regulations e.g. by means of the maximum permissible loading capacity of trucks. But even then uncertainties remain. What is the probability of an overloaded truck crossing the bridge or what will the future intensity of heavy loaded trucks be in relation to fatigue of the bridge material?

Four different levels of the probabilistic design approach can be discerned:

- *Level III: fully probabilistic approach*

$P_F$  is determined by means of numerical integration of the probability functions in equation (10.3) or by means of randomly drawn realisations of these functions ("Monte Carlo" approach), see section 10.2.3.

- *Level II: approximate probabilistic approach*

$P_F$  is approached by means of simplified functions, see section 10.2.4.

- *Level I: quasi-probabilistic approach*

For every parameter involved in load or strength a partial safety factor is used, e.g. one derived from a level II computation, see section 10.2.5.

- *Level 0: deterministic approach*

Some maximum load and minimum strength is taken based on experience and/or intuition (see Intermezzo 10-1) and one overall "safety factor" is applied. It will be clear that this is not a probabilistic approach at all. An overall safety coefficient,  $\gamma$ , usually says nothing about the safety, see Figure 10-4, where  $\gamma$  is the same for both cases, but  $P_F$  is completely different. Good engineering judgement requires a larger  $\gamma$  when the variation is larger.



Figure 10-4 Equal overall safety coefficient with different probability distributions

Another approach can be to work with characteristic values for load and strength, with a small chance that these values are too low or too high, see Figure 10-4. But even then, if the distribution of the extreme values is not known, the real meaning of  $\gamma$  is uncertain.

### 10.2.2 Comparison of methods

To illustrate the use of a traditional deterministic approach compared with the various levels of probabilistic approach, the following example are used, see Figure 10-5. A building is situated in the vicinity of the coastline and is protected by a rip-rap revetment, sufficiently high and including filter layers and a toe protection.

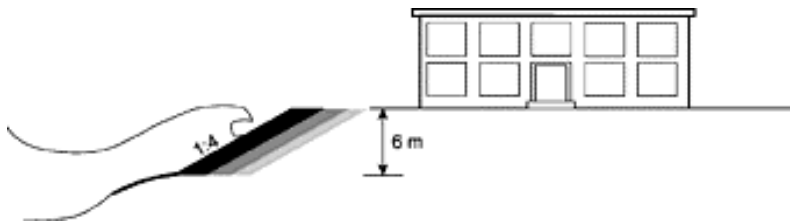

Figure 10-5 Example structure for comparison of probabilistic and deterministic approach

The idea is the following. Firstly, a design is made with a "traditional" deterministic approach (level 0). A characteristic wave height is chosen from the available wave observations and the threshold of motion is taken as a characteristic strength,. Subsequently, a fully probabilistic method (level III) is used to show what is a more realistic approach. Next, the results of level II and level I methods are shown to

illustrate the merits of these methods. Finally, a level 0 approach is applied again, using the results of the probabilistic methods, showing that common sense always pays. The example is simple and is meant as an educational tool, not as a practical application.

Ten years of wave observations are available, see Table 10-1. Only waves  $> 0.5$  m have been processed, as they are representative for "storms", lasting several hours. In these ten years, the highest recorded wave height was 1.62 m.

Table 10-1

Wave height interval (m)	Occurrences in 10 years	Exceedances in 10 years	Return period (yrs)
0.51-0.6	48	98	0.1
0.61-0.7	29	50	0.2
0.71-0.8	21		
0.81-0.9	6	20	0.5
0.91-1.0	4		
1.01-1.1	3	10	1
1.11-1.2	2		
1.21-1.3	2	5	2
1.31-1.4	1		
1.41-1.5	1	2	5
1.51-1.6	0		
1.61-1.7	1	1	10

### *Deterministic approach*

With the highest recorded wave height, the stone size for the top layer is calculated with the Van der Meer formula, see chapter 8:

$$d_{n50} = \frac{H_{sc} \xi^{0.5}}{\Delta 6.2 P^{0.18} \left( \frac{S}{\sqrt{N}} \right)^{0.2}} \quad (10.4)$$

Swell does not play a role at this coast, so for the wave steepness a value of 0.05 can be used. With a slope angle of 1:4 this means that only the plunging part of the formulas has to be used. The permeability,  $P$ , for a revetment on sand  $\approx 0.1$ ,  $\Delta \approx 1.6$  and the number of waves,  $N$ , is 7000 (maximum). The damage number,  $S = 2$  is chosen, as it is representative for the threshold of motion. This leads to  $d_{n50} = 0.56$  m and a choice of rock class 300-1000 kg ( $d_{n50} \approx 0.6$  m).

This can be seen as an example of a classical deterministic approach. Now, several probabilistic methods will be used to establish the risk of failure of this structure.

### Probabilistic approach

Probabilistic calculations will be done with the VaP package from ETH Zürich (see Petschacher, 1994). In a probabilistic approach, a limit-state function has to be defined. For this example the Van der Meer relation is rewritten:

$$Z = 6.2 P^{0.18} \left( \frac{S}{\sqrt{N}} \right)^{0.2} \xi^{-0.5} - \frac{H_{sc}}{\Delta d_{n50}} \quad (10.5)$$

Note that it is not strictly necessary to separate strength and load factors. If this  $Z$ -function  $< 0$ , the structure fails. With the values from the deterministic approach we find  $Z = 0.15$ , slightly positive since we used a larger stone (0.6 instead of 0.56 m).

Probability distributions for all parameters are used in the computation of the total probability. So, firstly, these distributions have to be estimated. The wave height distribution is determined from the available wave observations, see Table 10-1 and Figure 10-6.

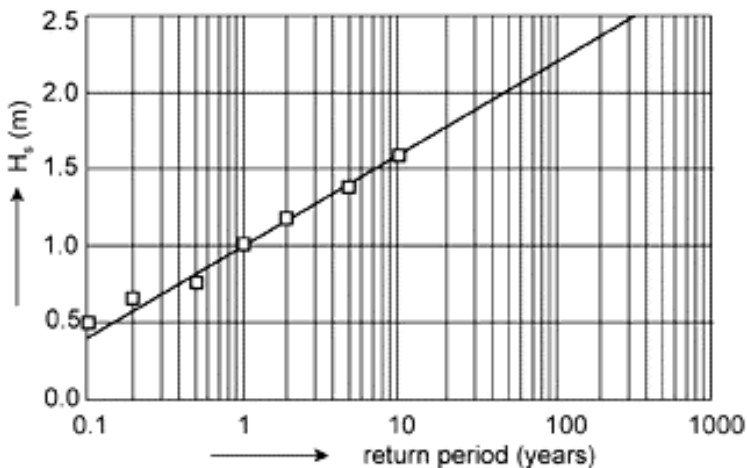

Figure 10-6 Long-term wave height distribution

In chapter 7 (Appendix 7.7.2) wave statistics were given for an irregular wave field. Such a wave field could be represented by the significant wave height,  $H_s$ , while the wave heights in a registration were described with a Rayleigh-distribution. So,  $H_s$  represents the wave condition at a certain moment, or better for a short period of one or more hours and the Rayleigh-distribution can be seen as the short term wave height distribution. All registered values of  $H_s$  give a distribution for the long term. This distribution is normally described with a Weibull-distribution, but often an exponential distribution gives reasonable results. Figure 10-6 shows an exponential distribution. This distribution has to be described mathematically to be used as input for the VaP-model.

The general expressions for the exponential distribution are:

$$f(x) = \lambda \exp(-\lambda(x - \varepsilon)) \rightarrow F(x) = 1 - \exp(-\lambda(x - \varepsilon)) \rightarrow (1 - F(x))^{-1} = \exp(\lambda(x - \varepsilon))$$

probability density                      probability  $X < x$                       return period

(10.6)

**Note:** the function is defined only for  $x \geq \varepsilon$  since negative probabilities are impossible, see second equation in (10.6).

Figure 10-6 gives the return period of the wave heights, so the parameters  $\lambda$  and  $\varepsilon$  have to be derived from the third equation of (10.6). This can be done by taking two values of the line in Figure 10-6, e.g. for return periods of 1 and 10 years:

$$\left. \begin{array}{l} 1 = e^{\lambda(1-\varepsilon)} \rightarrow \ln 1 = 0 = \lambda - \lambda\varepsilon \\ 10 = e^{\lambda(1.6-\varepsilon)} \rightarrow \ln 10 = 2.3 = 1.6\lambda - \lambda\varepsilon \end{array} \right\} \rightarrow \varepsilon = 1, \lambda = 3.83 \quad (10.7)$$

For  $d_{n50}$ ,  $\Delta$ ,  $\tan\alpha$  and  $s$ , a normal distribution is assumed. The mean values for these parameters are equal to the ones used in the deterministic approach: 0.6 m, 1.6, 0.25 and 0.05, respectively. The standard deviations are estimated as: 0.05 m, 0.1, 0.0125 and 0.01, respectively. P is assumed to have a log-normal distribution, to avoid errors caused by negative values of P in the calculation. The mean value is 0.1 and the standard deviation is 0.05. N is given a deterministic value of 7000.

**Note:** The normal distribution for  $d_{n50}$  is not a distribution curve within a stone class (e.g. a sieve curve). It represents the deviations in characteristic diameter for a whole mass of stones. Compare the Rayleigh-distribution within a wave record (characterized by  $H_s$ ) and the long-term distribution of  $H_s$ .

### 10.2.3 Level III

Numerical integration of Z is one of the available level III methods but will not be used here. Another method is the Monte Carlo method. The basis of this method is quite simple, see Figure 10-7. For all parameters, a random number is drawn, taking into account the probability distribution. This means that a value with a high probability density will appear more often. So, after many draws, the histogram of a normally distributed parameter will show the well-known Gauss-shape.

When all parameters have a value, the resulting value for Z is computed from equation (10.5). This whole procedure is repeated N times after which  $P_F$  simply is  $N_F/N$  ( $N_F$  being the number of times that  $Z < 0$ ). The procedure is simple but the number of repetitions is very high, which makes the Monte Carlo method a computer job par excellence.

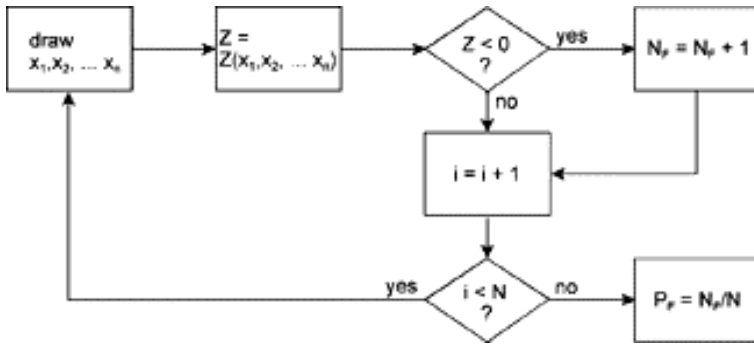

Figure 10-7 Procedure of Monte Carlo method

### Computations with $S = 2$

Figure 10-8 shows two realisations of the Monte Carlo procedure for  $S = 2$ , resulting in  $P_F = 0.095$  and  $0.091$ , respectively. The number of draws,  $N$ , determines the accuracy of the method. A rough estimate of the necessary value of  $N$  is:  $N > 400/P_F$ , so  $N$  has to be checked after  $P_F$  has been determined. An average, after three calculations,  $P_F = 0.094$ , which is the probability per year since the wave heights have been introduced as numbers of exceedance per year, see Figure 10-6. This value seems logical: the deterministic design was made with a 1/10 year wave (which has a probability of exceedance in one year  $\approx 0.1$ ) and a slightly larger stone was chosen ( $d_{n50} = 0.6$  instead of  $0.56$  m).

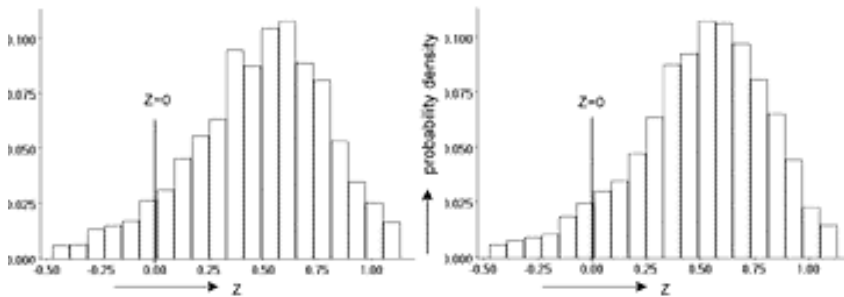

Figure 10-8 Realisations of Monte Carlo simulation

$S = 2$  was used in the deterministic approach. This can be seen as a Serviceability Limit State (SLS), beyond which some repair can be necessary. So, there is a 10% chance per year that some damage to the revetment will occur. This result is not really astonishing. But how safe is our building really? To judge the safety, it is necessary to determine the probability of damage to the building. This requires determination of the Ultimate Limit State (ULS).

### Computations with $S = 10$

The ULS will be approximated here simply with  $S = 10$ . The reason for this is as follows:  $S = 10$  indicates the damage when the top layer (which is about  $2d_{n50}$  thick) has been removed completely. Once the top layer removed, the filter layers, which have much less resistance against wave loads, will be removed as well. Underneath the revetment there is only sand. Equation 8.2 gives an idea of how far the coast will erode. With a wave of 1.6 m and fine sand, this will be about 40 m. This means collapse of the building near the shore. Implicitly it is assumed that the storm lasts for several hours, which is reasonable. So, although roughly,  $S = 10$  can indeed be seen as total failure.

The Monte Carlo simulation for  $S = 10$ , with all other parameters equal to those in the previous case, gives  $P_F = 0.011$ . So there is a 1% chance per year of total collapse of the building. Is this a problem? The lifetime of a building is normally many decades, say 50 years. The probability of collapse is then given by:

$$P_F \text{ in 50 years} = 1 - (1 - P_F / \text{year})^{50} = 0.42 \quad (10.8)$$

So, there is almost a 50% chance that this building will be destroyed during its lifetime! It should also be noted that even the best maintenance policy can not prevent this, since a storm that causes a damage level of 10 will also do so when the armour layer is still completely intact. The capitalized risk is:

$$R = \sum_{n=1}^{50} P_F D \frac{1}{(1+r)^n} = P_F D \frac{1 - \left(\frac{1}{1+r}\right)^{50}}{r} \quad (10.9)$$

in which  $D$  is the total damage and  $r$  is the interest rate.  $D$ , (including the economic activities related to the building) when  $S = 10$  is set to  $10 \cdot 10^6$  € and  $r$  is assumed to be 5%. The capitalized risk is then  $0.011 \cdot 10 \cdot 10^6 \cdot 18.25 = 2 \cdot 10^6$  €.

The final answer to this dilemma has to come from econometric considerations. These considerations are presented very simply. Revetments with various strength will be compared with a focus on costs and risk. For the involved risk, Table 10-2 gives the results of Monte Carlo computations and equation (10.9):

Table 10-2

Armour layer (kg)	$d_{n50}$ (m)	$P_F$ per year (-)	$P_F$ per 50 years (-)	Risk ( $10^6$ €)
60 - 300	0.4	0.189	0.999	34.5
300 - 1000	0.6	0.011	0.42	2.0
1000 - 3000	0.85	0.001	0.049	0.18
3000 - 6000	1.1	0.00017	0.0085	0.03

This has to be compared with the costs of the different revetments. Again, some simple assumptions will be made. The length of bank necessary to protect the building is assumed to be 200 m. The evolved length of the protection along the slope of the bank directly follows from the geometry of Figure 10-5:  $\sqrt{(6^2 + 24^2)} \approx 25$  m. The layer is taken  $2 \cdot d_{n50}$  thick. Only the costs of the top layer are different and one extra filter layer for the largest stone classes is needed. The costs of the other activities to construct the revetment (excavating, creating slope, filter layers, toe protection) are assumed to be  $1 \cdot 10^6$  € for all revetments. Table 10-3 gives the costs:

Table 10-3

Armour layer (kg)	Cost per m <sup>3</sup> (€)	Volume (m <sup>3</sup> )	Costs extra filter layer (10 <sup>6</sup> €)	Costs (incl. extra filter) (10 <sup>6</sup> €)	Total costs revetment (10 <sup>6</sup> €)
60 - 300	20	4000	0	0.08	1.08
300 - 1000	24	6000	0	0.14	1.14
1000 - 3000	30	9000	0.02	0.27	1.27
3000 - 6000	36	11500	0.02	0.42	1.42

The difference in costs is small: the initial costs to construct the revetment ( $1 \cdot 10^6$  €) are dominant. Comparison of costs and risks now shows the following picture, see Figure 10-9. It is obvious that stone class 1000-3000 kg instead of 300-1000 kg is a good choice, since the risk decreases with a factor 10 for just a small amount. Another solution could be a thicker top layer, permitting a larger  $S$  before the structure is endangered.

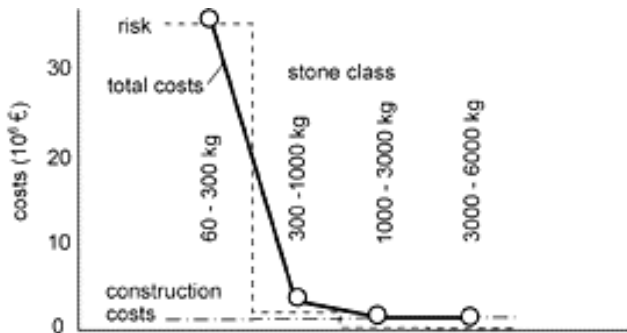

Figure 10-9 Risk and costs for various top layers

This choice becomes completely different when there is no expensive building directly on the shore. For example, if there is a protection, only to prevent further meandering of an estuary channel, the cost-risk ratio is completely different and the deterministic approach of section 10.2.2 is perfectly adequate (see also the evaluation in section 10.2.6).

### 10.2.4 Level II

The probabilistic level II approach is a collective term for approximate solutions of the failure probability by means of linearisation around a well-chosen point, the so-called *design point*. The limit-state function,  $Z$ , is described with a normal distribution just like all parameters that make up  $Z$ . This means that a deviating distribution of a parameter will be replaced by a normal distribution, which has the same value and slope in the design point as the original probability function. The failure probability, finally, is determined from the properties of the normally distributed  $Z$ -function,  $\mu_Z$  and  $\sigma_Z$  via, see also Figure 10-10:

$$\beta = \frac{\mu_Z}{\sigma_Z} \quad (10.10)$$

The failure probability  $P_F$  and  $\beta$  are directly related in the normal distribution and can be found in standard tables. So, if  $\beta$  can be derived from the known parameter distributions,  $P_F$  can also be known.

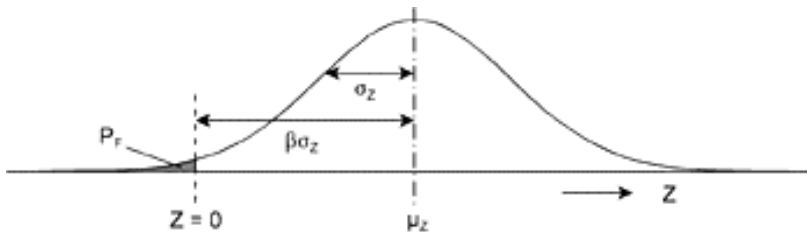

Figure 10-10 Failure probability in level II approach

The *design point* is the point on the line  $Z = 0$  where the probability density of the combination of load and strength has its maximum. When a structure fails, load and strength will probably have values near the design point values. The distance between the average value of a parameter and its design value is an indication of its importance with regard to  $\sigma_Z$  and, hence, to the failure probability of the structure. This importance is indicated with  $\alpha_i$  for each parameter. Appendix 10.6 can serve as an explanation if the procedure is not clear.

The VaP results for the original  $Z$ -function, equation 10.5, are:

Table 10-4

$\beta = 2.33, P_F = 0.0099$			
Parameter	$\alpha$ -value	$\alpha$ -value <sup>2</sup>	Design value
$H_s$	0.90	0.81	2.054 m
$d_{n50}$	-0.24	0.06	0.571 m
$P$	-0.25	0.06	0.068 -
$\Delta$	-0.18	0.03	1.557 -
$\tan\alpha$	0.07	0.01	0.252 -
$s$	-0.15	0.02	0.046 -
		$\Sigma=1$	

The influence of the wave height variation on the failure probability is clearly dominant. This is often the case; the load variations are more important than the strength variations.

Comparing the failure probability from the level II-analysis with the results of the Monte Carlo approach of section 10.2.3 gives an idea of the reliability of the level II method as a whole.  $P_F \approx 0.011$  is found with the Monte Carlo approach compared with  $P_F \approx 0.01$  from the level II approach. A difference of 10% is acceptable, since computations like this only serve to obtain an indication of the failure probability.

The advantage of a level II method is the resulting  $\alpha_i$ -values, which indicate the relative importance of a parameter in the total failure probability. The combination of a large  $\sigma_i$  and a large power in the Z-function lead to a high  $\alpha$ -value for a parameter. So, with good engineering judgement, a large  $\alpha$ -value does not come as a surprise and an engineer intuitively chooses a conservative value for such a parameter.

### 10.2.5 Level I

A level I approach adds nothing new to what has been said above. It is actually an application of the results of a higher-level method, especially level II methods. The approach requires a design value and a safety coefficient to be established for every parameter. The safety coefficients are derived from a level II computation, using the  $\alpha$ -values and  $\beta$ -value. The  $\beta$ -value stands for the required safety and the  $\alpha$ -values stand for the relative importance of each parameter. The partial safety coefficient for each parameter is then given by:

$$\gamma_i = \frac{\mu_i - \alpha_i \beta \sigma_i}{\mu_i} \quad (10.11)$$

$\alpha$ -values are negative for loads and positive for strength, leading to  $\gamma > 1$  for loads and  $< 1$  for strengths when used as a multiplier in both cases. Other definitions are possible and can be found in literature. The safety factors in equation (10.11) are defined with regard to the average values. When using other characteristic values, the

safety factor changes correspondingly. This approach can be seen as the application of engineering judgement as mentioned in the previous section.

### 10.2.6 Evaluation

In section 10.2.2 we started with a deterministic approach and compared the result with various levels of probabilistic methods. A deterministic method results in a certain strength (in the example the necessary stone class), given a certain load (in the example the wave height). A probabilistic approach results in a failure probability, given the distributions of load and strength. So, a probabilistic method never leads directly to dimensions for a structure. Given an acceptable failure probability, the dimensions have to be determined iteratively.

The risk analysis in section 10.2.3 showed that the deterministic approach led to an unacceptable high risk in the case of a building near the shore line. Would it have been possible to avoid this high risk without sophisticated probability models?

The deterministic approach was based on a wave height with a return period of 10 years and a low damage level,  $S = 2$ . From the risk analysis it became clear that the real issue is an acceptable low probability of failure of the building, equivalent to  $S = 10$ . Comparing the cost of a revetment, which is in the order of magnitude of 0.5 mln €, with the risk of collapse of a building of 5 mln €, the failure probability should be less than 10% during the lifetime of the building, which is about 50 years, say 5%. A convenient formula to deal with this issue is the Poisson-equation, which is an approximation of equation (10.8):

$$P = 1 - \exp(-fT) \quad (10.12)$$

in which:  $P$  = probability of occurrence of an event one or more times in period  $T$

$T$  = considered period in years

$f$  = average frequency of the event per year

For  $P = 0.05$  and  $T = 50$  years we find  $f = 1/1000$ . In other words: a wave height with a return period of 1000 years should be used. From Figure 10-6 we find:  $H_s \approx 2.8$  m. With  $S = 10$  in equation 10.4, this gives:  $d_{n50} \approx 0.7$  m. This would lead to a stone class 1000-3000 kg instead of 300-1000 kg. The same procedure could be applied to the maintenance. In that case a 10% chance of failure (SLS) or, in other words, the need for maintenance, is reasonable. This would lead to the same calculation as carried out in the deterministic approach of section 10.2.2 (once in 10 years wave height and  $S = 2$ ). In this case, however, the ULS is dominant. In the case where there is not an expensive building on the shore, maintenance is the only criterion.

***The Poisson equation (10.12) combined with common sense as outlined above can be seen as a semi-probabilistic approach which can serve as a very useful tool in a preliminary design.***

Of course, to establish the dimensions of a complex and important structure, like a storm surge barrier to protect a large and densely populated area, a probabilistic approach is an important design tool. Since probabilistic computations can only be done with some given structure, deterministic calculations are always carried out first and the final dimensions result from iteration between both approaches. A level III method is the best way to determine the failure probability. Level II methods are useful to get an insight into the relative importance of the various parameters involved.

Equation (10.12) can also be used to show other elementary statistical aspects:

- A common mistake is to design a structure with an envisaged lifetime of 5 years (e.g. a temporary situation during construction) with a load condition with a frequency of 1 per 5 years. Equation (10.12) shows that the probability that this load is reached or exceeded is  $1 - \exp(-1) \approx 0.63$ . So, there is a 63 % chance that conditions will be worse than assumed, which is usually not acceptable.
- In the case of a sea defence structure, to protect a low-lying area, it is impossible to define the lifetime of the structure since it is supposed to protect "forever". Assuming an acceptable probability of 1% in a human life (e.g. 75 years), instead of using the lifetime of the structure, equation (10.12) gives the frequency for the design conditions:  $f \approx 1/7500$  year which is quite a normal number for dangerous flooding hazards.

## **10.3 Maintenance**

### *10.3.1 Introduction*

Maintenance is essential for every structure. Throwaway products may also penetrate into engineering, but they will always be limited to parts of structures. Even then, the replacement of these parts is maintenance. Maintenance is primarily focused on the strength of a structure but monitoring of boundary conditions (e.g. sea level rise) can also be part of a maintenance program. Maintenance is therefore part of the management of a structure and consists mainly of inspection and repair. The total management policy links design, maintenance and the risk of failure of a structure, see also section 0 and Figure 10-1. A picture similar to Figure 10-1 can be drawn for an optimum maintenance strategy.

### *10.3.2 Maintenance policies*

Several maintenance policies are possible, depending on the predictability of the decrease of strength in time, the costs and possibilities of inspection and repair, and the consequences of failure. The different policies are, see also Vrijling et al., 1992 and CUR, 1991:

### Failure-based maintenance

Figure 10-11 shows the concept of failure-based maintenance. No action is taken until a structure, or part of it, fails. After that it is repaired or replaced by a new one. An example from every day life is a light bulb in a living room which is only replaced after it stops functioning. This is an efficient maintenance policy since the complete lifespan is used, but it is only permissible for non-essential parts with low risk. In hydraulic engineering this is no common practice.



Figure 10-11 Failure-based maintenance

### Time-based maintenance

If the deterioration can be predicted reasonably well, a time-based maintenance policy can be applied, see Figure 10-12. This is e.g. the case when the deterioration is governed by wear and tear due to the weather. An example from every day life is the painting of window frames of a house. An example from hydraulic engineering is painting a steel gate of a storm surge barrier.

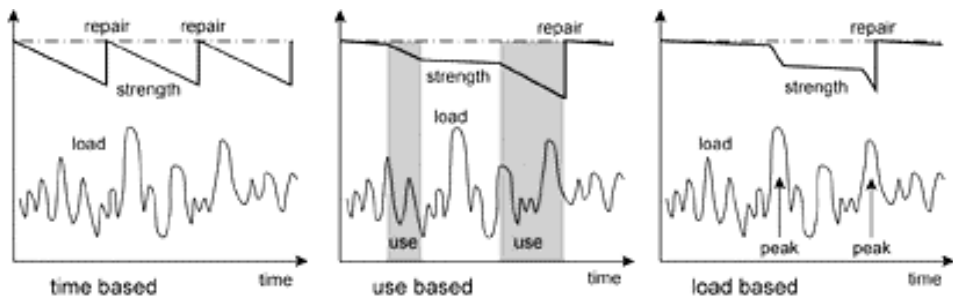

Figure 10-12 Time-, use- or load-based maintenance

### Use-based maintenance

Use-based maintenance depends on the usage of the structure. This is the case when the wear and tear is mainly a function of use intensity. An example from every day life is the overhaul of a car engine after so many km's. An example from hydraulic

engineering is the overhaul and repair, if necessary, of the machinery of a gate of a storm surge barrier.

### *Load-based maintenance*

When the deterioration is mainly governed by extreme loads, repair is carried out after the occurrence of an extreme load or after cumulation of loads. An example from everyday life is the replacement of safety belts in a car after a collision.

### *State-based maintenance*

This is probably the most common maintenance policy in hydraulic engineering. An example from everyday life is the repair of a roof which is inspected every now and then and treated when its state gives rise to repair. Examples from hydraulic engineering are revetments.

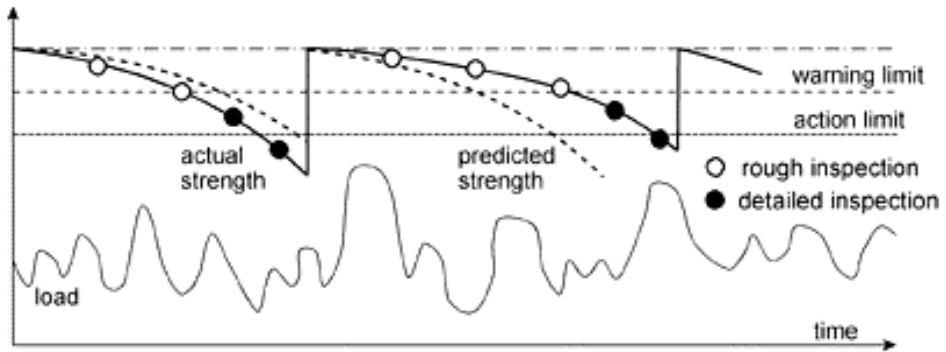

Figure 10-13 State-based maintenance

Figure 10-13 gives the procedure for state-based maintenance. The structure is inspected roughly at fixed intervals, based on the expected and predicted decrease of strength. After some warning limit state is reached, the inspections become more frequent and more detailed. When the action limit state is reached, repairs have to be carried out.

Figure 10-14 shows how to arrive at the best maintenance policy. In this picture monitoring means keeping track of time or of usage or of the load that the structure has been subjected to. Inspection has to be done on the spot.

In practice, a mixture of the various policies is often used. E.g. in addition to a time-based policy, inspection can lead to postponing repair if the state of the structure is better than expected. In general, one can say that inspection reduces the uncertainties in the parameters.

Which maintenance policy is most appropriate, depends on the consequences of failure and the predictability of the strength as a function of time, see Figure 10-14.

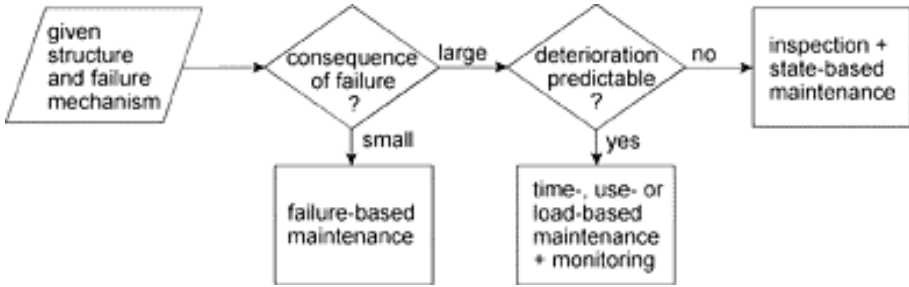

Figure 10-14 Choice of maintenance policy

10.3.3 Probabilistic approach of inspection

An outlet sluice is constructed with a bottom protection to avoid damage due to scour. The apron is just long enough to prevent collapse of the sluice structure if a slide occurs in the scour hole. Before that happens, the slope of the scour hole should be covered with slag material or gravel. If the slope slides, the scour depth is an estimated 8 m (the critical scour depth) and the slope angle after sliding is estimated to be 1:6, leading to a necessary apron length of say 50 m, see Figure 10-15a and chapter 4 for further details.

**Note:** Of course, the stability of a scour hole depends heavily on the geotechnical properties of the soil and the upstream slope of the scour hole. All of these factors have been simplified in this example into one parameter, the critical scour depth:  $h_{sc}$ . The scour depth as a function of time is determined with the Breusers-equation, see chapter 4:

$$h_s(t) = \frac{(\alpha \bar{u} - \bar{u}_c)^{1.7} h_0^{0.2}}{10 \Delta^{0.7}} t^{0.4} \tag{10.13}$$

This function can be rewritten as a limit state function:

$$Z = h_{sc}(t) - \frac{(\alpha \bar{u} - \bar{u}_c)^{1.7} h_0^{0.2} t^{0.4}}{10 \Delta^{0.7}} \tag{10.14}$$

The following values are assumed in these equations (all parameters with normal distributions):

Table 10-5

Parameter	$\alpha$	$\bar{u}$	$\bar{u}_c$	$h_0$	$\Delta$	$h_{sc}$
Mean ( $\mu$ )	2.5	1 m/s	0.5 m/s	10 m	1.65	8 m
Deviation ( $\sigma$ )	1	0.1 m/s	0.05 m/s	0.25 m	0.05	2 m

The most uncertain parameters are  $\alpha$  and  $h_{sc}$ , hence they get a large deviation. Figure 10-15b shows the development of the scour depth as a function of time according to equation (10.13), using the average value of Table 10-5 ( $\alpha = 2.5$ ).

*Note:*  $\alpha$  is used as a turbulence parameter in equation (10.13) and in the probabilistic approach it is used as an influence parameter.

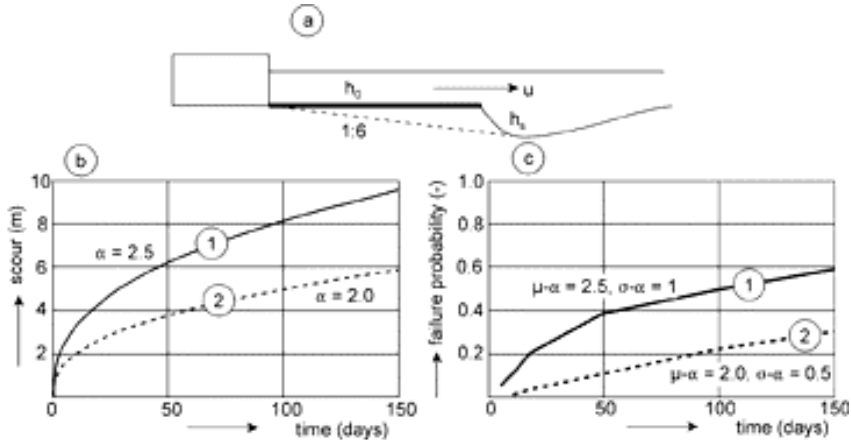

Figure 10-15 Failure probability scour hole

The question now is how soon and how often should the scour depth be sounded in order to know when the scour slope has to be covered, e.g. when the hole is 5-6 m deep. A level II analysis (with VaP) is carried out with the other values in Table 10-5 with time,  $t$ , (effective flow time in days) as a deterministic parameter with different values. Figure 10-15c shows the results (upper line). According to equation (10.13) the critical scour depth of 8 m will be reached after 95 days (Figure 10-15b). Figure 10-15c shows that there is a 50% probability that the depth is indeed 8 m after 95 days. This is, of course, logical: with all parameters normally distributed, there is 50% chance that the value is higher and 50% chance that it is lower. No matter how large the deviations, the Gauss-curve is centred around the expectation value.

But a probability of 50% is very high and the risk is unacceptable. So, the responsible manager will not postpone inspection till the expected critical depth is reached according to equation (10.13). When a low probability is considered acceptable, e.g. 5%, Figure 10-15c shows that inspection should be carried out after 5 days of effective flowing time! Sounding is not very expensive and this can be seen as a test run of the new sluice.

During the first 20 days of use of the sluice, more soundings can be done and the result could be that the scour development is not along line 1 in Figure 10-15b, but along line 2. This means that the estimated  $\alpha$ -value (determined either by rough estimates as illustrated in chapter 4, or by considering the results of model tests) was too pessimistic. With the results of the soundings, a new value for  $\alpha$  can be

determined (assuming that the values for the other parameters are correct). The  $\alpha$ -value for line 2 is 2 for which, again, a probabilistic calculation can be carried out. The results are directly valid for the considered structure, so a lower deviation can also be assumed, e.g. 0.5 instead of 1, as was the case in Table 10-5. Line 2 in Figure 10-15c shows the results for the new probability failure. The next inspection could be after 50 days of flow. If the scour process is still according to line 2 in Figure 10-15b, the slope could be covered after 100 to 150 days flow time.

*Note: When applying a lower  $\alpha$ -value based on soundings, one should be sure of the composition of the soil. If the upper layer consists of a more resistant layer with some cohesion, scour can accelerate again after breaking through this layer.*

This example demonstrates the use of inspection in maintenance. The costs are not prohibitive and it reduces the uncertainty about the strength, hence it increases the predictability of the behaviour of the structure.

## 10.4 Failure mechanisms

### 10.4.1 Introduction

Chapter 1 already stated that it is paramount for a designer to have an idea of the different failure mechanisms of a hydraulic structure. It is repeated once again that *most structures fail, not because the incoming wave height has been underestimated with 10 or 20 %, but because a failure mechanism has been neglected.* The contents of chapter 1, concerning fault trees, will be further elaborated on relating them to probabilistics and illustrating them with some examples.

### 10.4.2 Systems

A systems approach to the design of a hydraulic structure is a rather abstract notion, but it can serve to illustrate some important elements of a design. Two important concepts in structural systems are series and parallel systems, see Figure 10-16. In a series system, every broken element means total failure. In a parallel system, the function of a broken element can be transferred to other elements. An example of a series system amongst protections is the various possible slip circles in a slope, see chapter 5. The weakest circle determines the safety. An example of a parallel system is a single slip circle in non-homogenous soil. Strong soil layers can compensate for weak parts in the soil, as all layers contribute to the total resistance.

A series system consisting of two or more elements, has a total probability of failure between:

$$\max P_{Fi} \leq P_{F-tot} \leq \sum P_{Fi} \quad (10.15)$$

The lower boundary is valid if there is full correlation between the elements, or in other words, if failure of each element is coupled to failure of the other elements. The upper boundary is valid if there is no correlation at all between failure of the elements. In that case the total probability is the sum of all partial probabilities.

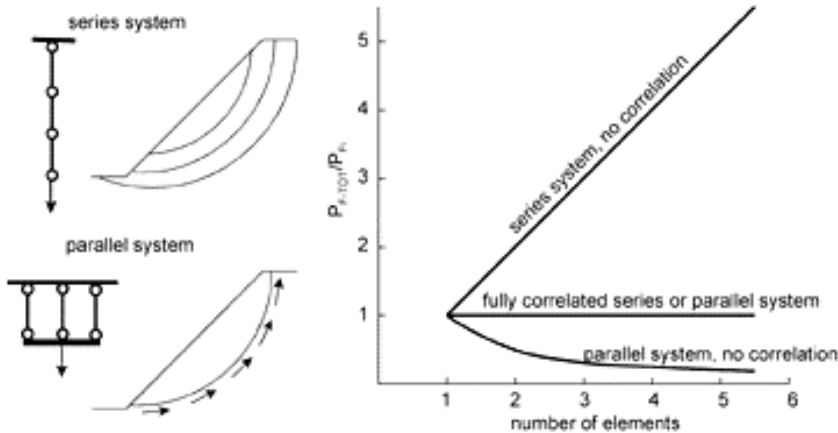

Figure 10-16 Series and parallel systems

For a parallel system, the total probability is given by:

$$P_{F1} \cdot P_{F2} \cdot \dots \cdot P_{Fn} \leq P_{F-tot} \leq \max P_{Fi} \quad (10.16)$$

Now the lower boundary (a multiplication of all of the probabilities) is valid without any correlation and the upper boundary represents failure with full correlation.

The first thing that is striking is that there is no difference between the total probability of failure of series and parallel systems if they have fully correlated elements. Figure 10-16 shows the extremes of equations (10.15) and (10.16) for elements with equal  $P_{Fi}$ . For partial correlations between the elements, the total probability lies between the extremes in this figure.

For a practical application, much statistical data is needed for all parts of a structure. This is beyond the scope of this book, the reader is referred to CUR, 1995. A qualitative conclusion is that series systems should be avoided wherever possible and that the system should contain enough redundancy. An example is a dike with a protection layer of blocks and a body of sand or clay. With a sand body, severe damage of the protection layer will quickly lead to breach of the dike, while a clay body can resist the wave load in a storm for many hours.

#### 10.4.3 Fault trees

In chapter 1 a rough fault tree for a revetment was presented. Here we will go into more detail. The series and parallel systems of section 10.4.2 also play a role in fault

trees. A series system is represented in a fault tree by a so-called 'OR'-gate, indicating that failure of one of the elements leads to failure of the system under consideration. An 'AND'-gate represents a parallel system: failure of both elements is necessary for failure of the system.

Figure 10-17 shows a (simplified) fault tree for a caisson on a sill as part of a closure dam. Water flows through the open caissons. The flow can cause erosion of the top layer of the sill and the head difference can cause erosion of the subsoil through the filter. Both directly cause collapse of the caisson, hence an OR-gate in the fault tree. Both phenomena are independent, hence not correlated and the probability of collapse of the caisson is the sum of the probabilities of both. Scour can cause a slide when there is insufficient inspection. If a slide occurs in loosely packed sand, this can lead to liquefaction and subsequently to a flow slide, see chapter 5. A flow slide and a short bottom protection can lead to collapse of the caisson. All of these combinations are AND-gates because both conditions are necessary to induce the next step.

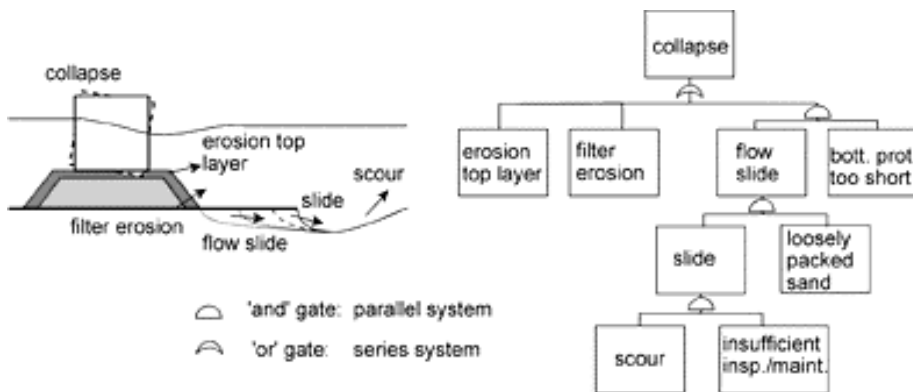

Figure 10-17 Series and parallel systems in fault tree

The fault tree for a revetment given in chapter 1 is reproduced in some more detail in Figure 10-18. Now (fictitious) probabilities (per year) have been added. Most elements form series systems where the total probability is the sum of the partial probabilities. When a partial probability is an order of magnitude smaller than the dominant mechanism, it can be neglected, see the initial geotechnical instabilities compared with the toe erosion.

Toe erosion and instability of the top layer have a probability equal to the hydraulic conditions that cause them. This is the case when the design has been based on a deterministic approach, see also section 10.2.2. The combination of wave conditions and subsidence of the soil form a parallel system, giving a probability of wave overtopping equal to the multiplication of both partial probabilities. In the series

system of local instability this appears negligible compared with the other mechanisms.

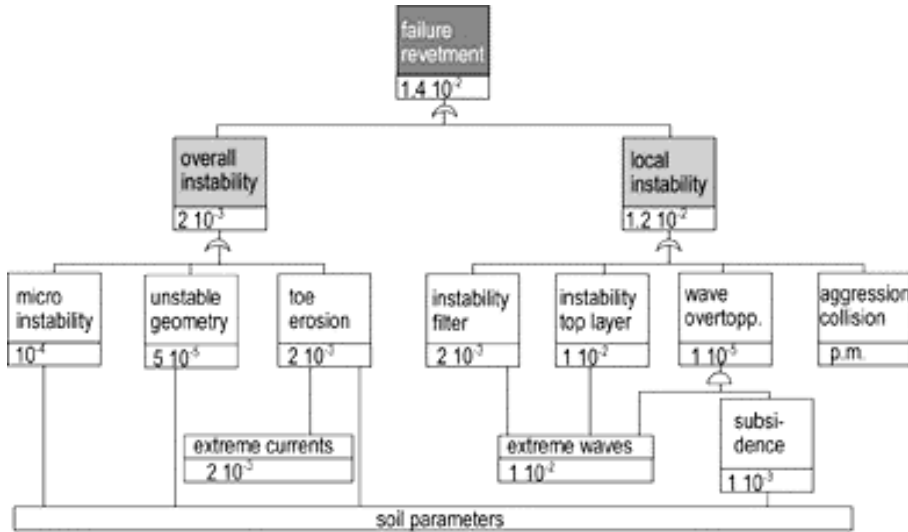

Figure 10-18 Fault tree revetment with probabilities

The use of fault trees lies mainly in the awareness of weak spots of a structure. It is extremely difficult to establish a reliable absolute value for the total probability. It is often advantageous to go through a fault tree bottom-up and top-down and, if necessary, several times. When going bottom-up, the conclusion can be that a probability somewhere in the system is too high, leading to an adaptation of a detail in the design. When going top-down, one can start with an acceptable probability of the top event and see what has to be done to each mechanism to reduce the probability to this value. In the fault tree in Figure 10-17 it is obvious that erosion of the sill is more dangerous than scour. So, the probability of erosion of the sill has to be kept low.

#### 10.4.4 Examples

This section gives some examples from the hydraulic engineering practice concerning cases where one or more failure mechanisms have been neglected, leading to failure of a structure with large consequences. Starting point is, again, the fault tree of Figure 10-18.

##### *Wave overtopping*

If wave overtopping is underestimated, the result can be as shown in Figure 10-19, an example from Australia. The top layer seems strong enough and filter layers have also been included in the design. However, due to overtopping, wave action eroded the unprotected soil on the crest of the revetment, leading to its total collapse.

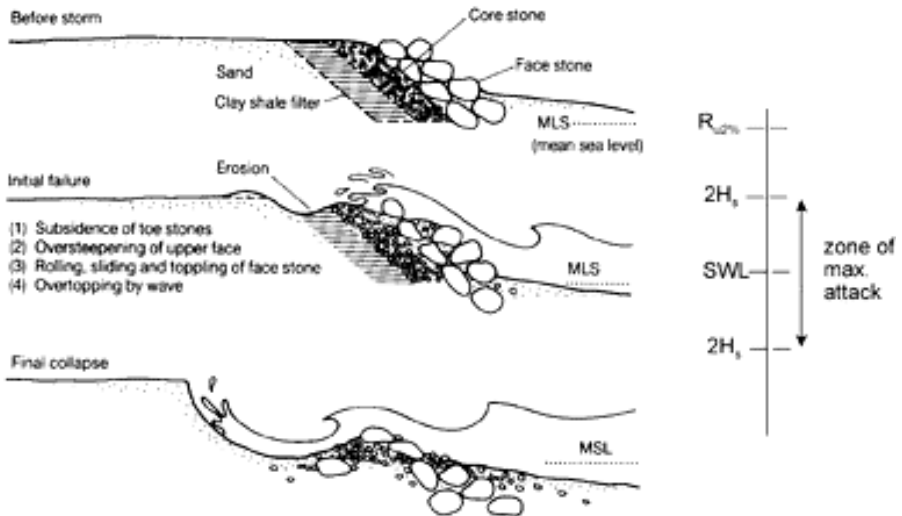

Figure 10-19 Collapse due to wave overtopping

### *Toe erosion*

A bridge with an abutment was built across a river in Bangladesh, see Figure 10-20. Due to the meandering of the river, the location of the abutment suffered severe erosion. The revetment of the abutment consisted of a concrete slab and a sheet pile. This sheet pile had been driven only a few meters into the subsoil and had not been secured against erosion of the foreland. The sheetpiles were undermined and the stiff concrete slab cracked leading to the final collapse of the abutment. Repair work could be carried out before the bridge itself was damaged.

The abutment, situated in the outer bend of the meandering river, should have been designed to be able to withstand the erosion process at the toe of the revetment, which had a probability of occurrence of about 100%. Either a much longer sheetpile or an extensive toe protection in the initial design would have been the result.

### *Wave overtopping and micro-stability*

In 1953 many dikes in the south western part of The Netherlands collapsed. The crest level of these dikes was too low and the inner slopes were too steep (1:1.5 - 1:2). The water on the crest penetrated into the slope and the resulting groundwater flow, combined with the steep slope, led to an unstable situation, see also chapter 5.

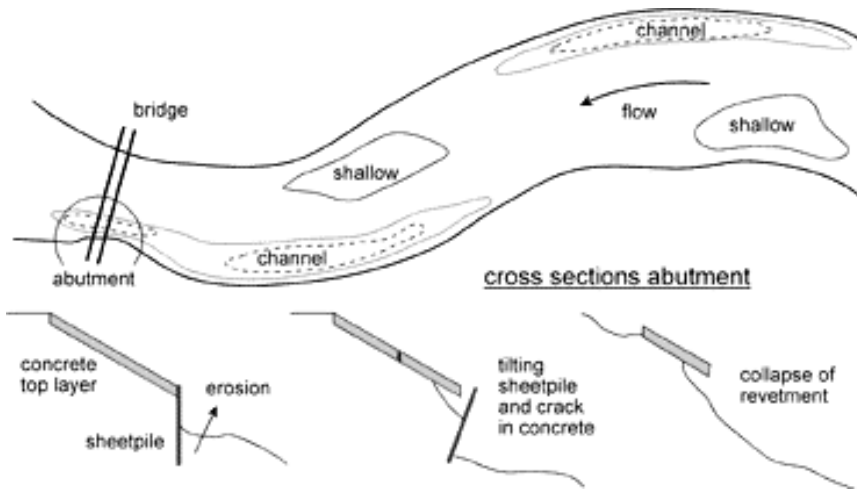

Figure 10-20 Collapse due to toe erosion

### *How useful are fault trees?*

The ultimate question is whether all this could have been prevented if a fault tree had been used. Of course, the use of the fault tree in Figure 10-18, would have led to awareness of the erosion at the toe of the abutment in Figure 10-20 and of the wave overtopping of the revetment in Figure 10-19. These phenomena are already mentioned in the tree, so one is forced to think about it. But how can all failure mechanisms be included if one has to make a fault tree for a new case, as, by definition, you omit what you overlook? In the case of the dikes of Figure 10-21, the probability of high water levels was insufficiently recognized, see Intermezzo 10-1, and the instability of the inner slopes was insufficiently understood at that time. Elements (dolos) of large breakwaters have been known to break due to high stresses in the concrete, a mechanism that had not been included in any fault tree.

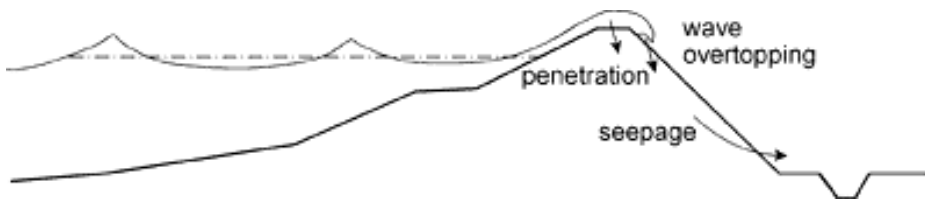

Figure 10-21 Collapse of dike due to micro-instability

So, a fault tree can be useful but it offers no guarantee that nothing has been overlooked or underestimated. The general message in this book is that insight and knowledge of the phenomena is essential. Without that, a fault tree is useless. A brainstorm session with people of various backgrounds can be very helpful to avoid omitting mechanisms in a fault tree. The first part of the brainstorm session can just

be summing up possible failure mechanisms. The second part can be trying to establish the probability of every mechanism, in some cases only in a qualitative way. The use of a fault tree is then a powerful tool to avoid blunders and to recognize weak spots in a design.

## 10.5 Summary

*Starting with the general notion:*

$$\mathbf{Risk = probability * consequence}$$

*the probabilistic approach of a design is treated. A reliability function is defined:*

$$\mathbf{Z = strength - load}$$

*from which the failure probability follows:*

$$\mathbf{P_F = P(Z < 0)}$$

*This approach can be elaborated on various levels:*

**Level III:** *a full (numerical) integration of Z, or a Monte Carlo approach, where the various parameters that make up Z get a value according to their probability distribution. In the Monte Carlo approach, a structure is built and tested, as it were, say 10000 times, the number of times the structure fails gives the failure probability.*

**Level II:** *Z, and all underlying probability distributions are assumed to have a normal distribution again resulting in the establishment of  $P_F$  and influence factors of all parameters involved ( $\alpha$ ).*

**Level I:** *starting with a desired  $P_F$  and the influence factors from a level II approach, a partial safety coefficient for each parameter is defined.*

**Level 0:** *a semi-probabilistic or deterministic approach based on experience in which design values for loads and strengths are selected. The Poisson distribution:*

$$\mathbf{P = 1 - exp (-fT)}$$

*can be a useful tool when a design value for the load is to be established.*

*Several ways of maintenance are mentioned. For protections, a state-based maintenance approach is usually the most appropriate. Inspection is an essential part of a state-based maintenance approach.*

*An overview of all relevant failure mechanisms is essential to be able to create a “fool proof” design. This overview can best be presented by combining the mechanisms in a fault tree. A brainstorm session with several experts can help to avoid overlooking a relevant mechanism. This is important, since most structures do*

not fail because of an underestimation of the load, but due to an important failure mechanism which has been overlooked.

## 10.6 Appendix: Probabilistic approach Level II

In this appendix, the algorithm to come to a failure probability will be given by means of a simple example. The following iterative procedure is to find  $\beta$ ,  $\alpha_i$  etc.:

1. Estimate  $\mu_Z$  from  $Z$  and the estimated values of the various parameters in the design point:

$$\mu_Z = Z(x_1^*, x_2^*, \dots, x_n^*) + \sum_{i=1}^n \frac{\partial Z}{\partial x_i} (\mu_{x_i} - x_i^*) \quad (10.17)$$

As a first estimate for  $x_i^*$ ,  $\mu_{x_i}$  can be used.

2. Determine  $\sigma_Z$  from the contribution of the various parameters to the variation of  $Z$ :

$$\sigma_Z = \left[ \sum_{i=1}^n \left( \frac{\partial Z}{\partial x_i} \right)^2 \sigma_{x_i}^2 \right]^{1/2} \quad (10.18)$$

3. Calculate  $\beta$  from equation (10.10)

4. Determine the  $\alpha$ -values (which indicate the influence on  $P_F$ ) for each parameter from:

$$\alpha_i = \frac{\partial Z}{\partial x_i} \frac{\sigma_{x_i}}{\sigma_Z} \quad (10.19)$$

This shows that both an important role of  $x_i$  in  $Z$  (indicated by  $\partial Z / \partial x_i$ ) and a large uncertainty about the value of  $x_i$  (indicated by  $\sigma_{x_i}$ ) are responsible for a large  $\alpha$ -value.

5. Make a new estimate for the design-point values with:

$$x_i^* = \mu_{x_i} - \alpha_i \beta \sigma_{x_i} \quad (10.20)$$

6. Find a substituting normal distribution for not-normally distributed parameters for the design-point value of the parameter.

These steps are to be repeated until the design-point values have converged with sufficient accuracy. With the final value of  $\beta$ , the failure probability,  $P_F$ , is derived from the standard normal distribution.

For a limit-state function with many parameters, a computer is the most suitable instrument to do the job. However, in order to enlarge the insight into this method, an example for the revetment in section 10.2.2 will be shown with further

simplifications. The limit-state function for the revetment will be reduced to just two variables, which are representative for load and strength. This has three advantages: the joint probability of load and strength can be easily visualized, contributing to a better understanding, the iteration can be shown with a manual computation and an "exact" solution by means of numerical integration (level III) can be obtained.

### *Simplified Z-function*

The Z-function according to equation (10.5) is simplified further. Only the most important parameters concerning load ( $H_s$ ) and strength ( $d_{n50}$ ) are defined as random variables. Again, the wave heights are assumed to have an exponential distribution (10.6). The iteration to find the design point, needs to be started with the average value,  $\mu$ , and standard deviation,  $\sigma$ , of the parameters. For an exponential distribution,  $\mu$  and  $\sigma$  are given by:

$$\mu_H = \varepsilon + \frac{1}{\lambda} = 1.26 \quad \sigma_H = \frac{1}{\lambda} = 0.26 \quad (10.21)$$

see also equation (10.6) and mathematical textbooks.

For the stones the same, normally distributed diameter is chosen ( $\mu_d = 0.6$  m,  $\sigma_d = 0.05$  m). The other parameters will be defined as deterministic parameters, using the values in section 10.2.2 with  $S = 10$ . The Z-function (10.5) then reduces to:

$$Z = 2.533 - \frac{H_s}{1.6d_{n50}} \quad (10.22)$$

The first step in the iteration is to find  $\mu_z$  with  $\mu_{x_i}$  as first estimate for the design point values. Note that now the second member on the right-hand side of equation (10.17) is 0. We find  $\mu_z = 1.22$  m.

$\sigma_z$  is determined from equation (10.18) again with  $\mu_{H_s}$  en  $\mu_{d_{n50}}$  as first estimates:

$$\frac{\partial Z}{\partial H_s} = \frac{-1}{1.6d_{n50}} \quad \frac{\partial Z}{\partial d_{n50}} = \frac{H_s}{1.6d_{n50}^2} \quad (10.23)$$

leading to  $-1.042 \text{ m}^{-1}$  and  $2.188 \text{ m}^{-1}$  respectively. From equation (10.18) we then find  $\sigma_z = 0.292$  and from equation (10.19):  $\alpha_{H_s} = -0.927$  and  $\alpha_{d_{n50}} = 0.374$ . Equation (10.10) gives  $\beta = 4.179$  and equation (10.20):  $H_s^* = 2.267$  m and  $d_{n50}^* = 0.522$  m.

The next step in the iteration procedure is to replace the exponential distribution for  $H_s$  with a normal distribution which has the same probability density and probability in the design point,  $H_s^*$ . This is done by equating:

$$3.83 \exp(-3.83(H_s^* - 1)) = \frac{\exp\left(-0.5 \left(\frac{H_s^* - \mu_{H_s \text{ normal}}}{\sigma_{H_s \text{ normal}}}\right)^2\right)}{\sigma_{H_s \text{ normal}} \sqrt{2\pi}} \quad (10.24)$$

and:

$$1 - \exp(-3.83(H_s^* - 1)) = \int_{-\infty}^{H_s^*} \frac{\exp\left(-0.5 \left(\frac{H_s^* - \mu_{H_s \text{ normal}}}{\sigma_{H_s \text{ normal}}}\right)^2\right)}{\sigma_{H_s \text{ normal}} \sqrt{2\pi}} dH_s^* \quad (10.25)$$

The left-hand side of equation (10.25) is equal to 0.9922. This probability is equivalent to a  $\beta$ -value for the normal distribution of 2.42, which can be found in standard tables and which is equal to  $(H_s^* - \mu_{H_s \text{ normal}}) / \sigma_{H_s \text{ normal}}$ . From the equations (10.24) and (10.25), with the  $H_s^*$ -value from the first iteration, we then find the two unknowns:  $\mu_{H_s \text{ normal}} = 0.495$  and  $\sigma_{H_s \text{ normal}} = 0.735$ .

The iteration is now repeated with the value for  $H_s^*$  from the first iteration and using  $\mu_{H_s \text{ normal}}$  and  $\sigma_{H_s \text{ normal}}$  in equations (10.17) and (10.18) leading to a new value for  $H_s^*$ , and subsequently with equations (10.24) and (10.25) leading to new values for  $\mu_{H_s \text{ normal}}$  and  $\sigma_{H_s \text{ normal}}$ .

Note that at the start the second member on the right-hand side of equation (10.17) was 0, while in the end the first member will be zero, since the design point is situated on the  $Z = 0$  line ( $Z[x_i^*] = 0$ ). The second part then represents the average value of  $Z$  as "predicted" from the design point:  $\partial Z / \partial x_i \cdot (\mu_{x_i} - x_i^*)$ .

Finally this leads to:

Table 10-6

$\beta = 2.55, P_F = 0.0054$				
Parameter	$\alpha$ -value <sup>2</sup>	$\mu$ (normal)	$\sigma$ (normal)	Design value
$H_s$	0.93	0.508 m	0.728 m	2.293 m
$d_{n50}$	0.07	0.6 m	0.05 m	0.566 m
	$\Sigma=1$			

It is clear that the variations of the wave height are dominant in the results (compare  $\alpha$ -values). Note that  $\alpha$ -values for loads are negative and for strength positive. Since equation (10.22), the simplified  $Z$ -function, has only two (independent) random variables, the probability density can be computed from:

$$p(Z) = p(H_s) \cdot p(d_{n50}) = \frac{3.83 \exp(-3.83(H_s - 1))}{0.05\sqrt{2\pi}} \exp\left(-0.5\left(\frac{d_{n50} - 0.6}{0.05}\right)^2\right) \quad (10.26)$$

From this function, the failure probability can be found directly by numerically integrating the probability density, in accordance with equation (10.3). This has to be done for all values  $H_s > 1$  m (for which the wave height distribution is valid) and knowing that (from equation (10.22))  $Z < 0$  for  $H_s > 4.05d_{n50}$  :

$$P_F = \iint_{H_s > 4.05d_{n50}} \frac{3.83 \exp(-3.83(H_s - 1))}{0.05\sqrt{2\pi}} \exp\left(-0.5\left(\frac{d_{n50} - 0.6}{0.05}\right)^2\right) dd_{n50} dH_s \quad (10.27)$$

This integration gives:  $P_F = 0.0057$  which is the "exact" solution for this simplified case (Level III, numerical integration). This number, compared with Table 10-6, is only slightly different, thus an approximation with a level II approach gives reasonable results.

The final results can also be presented graphically, further clarifying the approach and the meaning of the various notions in the equations. Figure 10-22 shows lines of equal probability density from equation (10.26) together with lines of equal  $Z$  from equation (10.22). The lines of equal probability density are the contourlines of the probability mountain (see also Figure 10-3). The design point indeed appears to be situated on the line  $Z = 0$ .

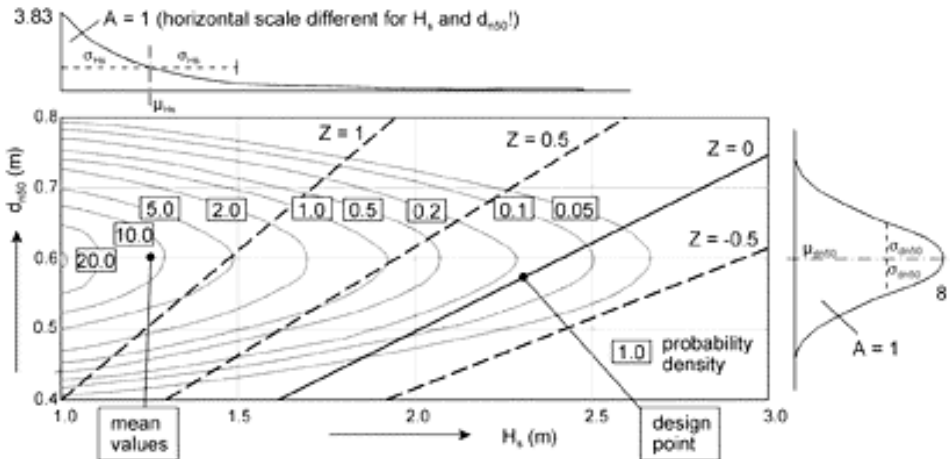

Figure 10-22 Top view of probability mountain, simplified case

As said before (in section 10.2.1), the volume of the part of this mountain where  $Z < 0$ , divided by the total volume gives the failure probability. This part was calculated directly with equation (10.27).

Figure 10-23 is a 3-dimensional representation of Figure 10-22. Figure 10-23a gives a view of the  $Z$ -plane.  $\partial Z/\partial H_s$  and  $\partial Z/\partial d_{n50}$ , as used in equations (10.17), (10.18) and (10.19), are the slopes in the  $d_{n50}$ - and  $H_s$ -directions at the design point. Figure 10-23b represents the design point on the flanks of the probability mountain showing that the probability density indeed has its maximum in the design point.

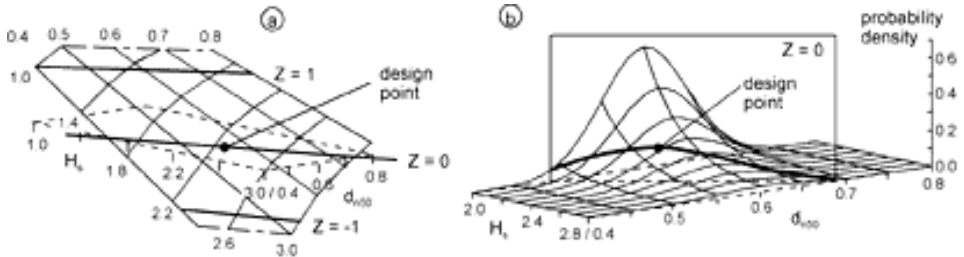

Figure 10-23 3-dimensional view of  $Z$ -function and probability mountain with design point

Figure 10-24, finally, shows the equivalent normal distribution of the wave heights as derived from equations (10.24) and (10.25). Again, the intersection and the tangent of the two distributions are at the design point.

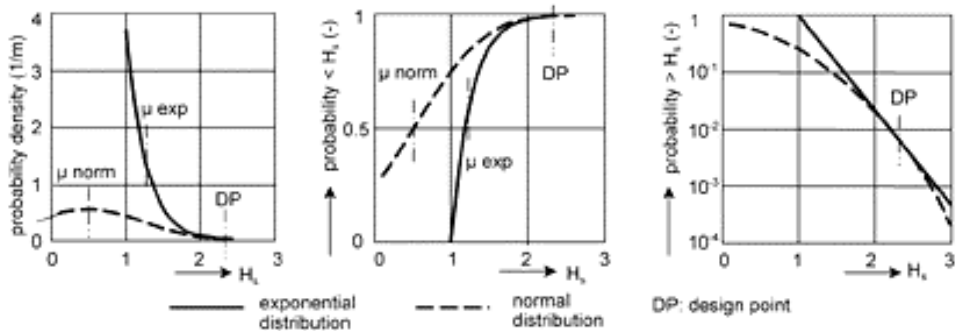

Figure 10-24 Exponential distribution and substitute normal distribution

Only two variables were included in the limit state function to make the example as clear as possible. The manual computations as executed above can serve as an algorithm also for more than two variables. This algorithm results in a simple computer program for a level II approach.